



HOSHIZAKI

IM - 65PE - LM

Model Number
91000177

38KG XXL Cube Ice Maker, Self Contained



Hoshizaki IM-65PE-LM Cube model is a self-contained ice maker producing up to 42kg (10°C Air temp; 10°C Water) of cube ice per 24 hours.

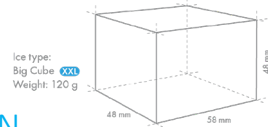

- Produces compact, dry, tasteless and slow melting cube ice, allowing just the right amount of dilution.
- Automated cleaning (wash auto-restart).
- Water circuit cleaning notification.
- Condenser cleaning notification.
- Magnetic dc pump motor with variable speed.
- High grade stainless steel.
- Stand-by/wash buttons.
- Removable door gasket.
- Easy-clean air filter.

PRODUCT SPECIFICATION

Ice Type	Cube XXL
Production Capacity per 24hours	Approx. 42kg @ 10°C Air temp; 10°C Water Approx. 38kg @ 21°C Air temp; 15°C Water Approx. 31kg @ 32°C Air temp; 21°C Water
Max Storage Capacity	Approx. 26kg (Bin Control Setting Approx. 18kg)
Dimensions	633mm (W), 506mm (D), 950mm (H)
Weight Net Packed Weight	54kg 64kg
Cooling	Air
AC Supply Voltage	1 PHASE 220-240V 50Hz/ 10 AMP Plug
Refrigerant	R290
Operating Conditions	Ambient Temp.: 1-40°C Water Supply Temp.: 5-35°C Water Supply Pressure: 0.07-0.8MPa (0.7 - 8bar) Voltage Range: Rated Voltage ±6%
Water Consumption Per 24h	Approx. 0.30m ³ @ 10°C Air temp; 10°C Water Approx. 0.08m ³ @ 21°C Air temp; 15°C Water Approx. 0.07m ³ @ 32°C Air temp; 21°C Water
Heat Rejection (AT 32°C, WT 21°C)	830W
Accessories included	Installation kit, Scoop
GEM Number	AIM0008

INSTALLATION REQUIREMENTS

- Ensure the condenser is cleaned periodically as per the manufacturer's manual.
- Do not plug the unit into multi-plug power boards with other appliances
- Room ventilation or air conditioning can improve the situation by reducing the humidity.
- Hoshizaki recommends the use of a compatible water filter to prevent non-warrantable scale & sediment complications.

*Refer to manual for full installation & maintenance requirements.



For free 6 month extended warranty, register online within 4 weeks of purchase date.
hoshizaki.com.au



HOSHIZAKI

IM - 65PE - LM

38KG XXL Cube Ice Maker, Self Contained

TECHNICAL DRAWING

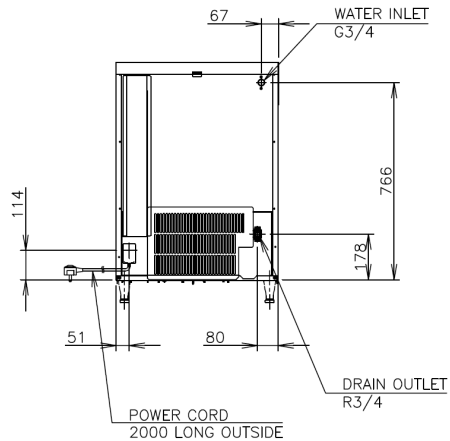
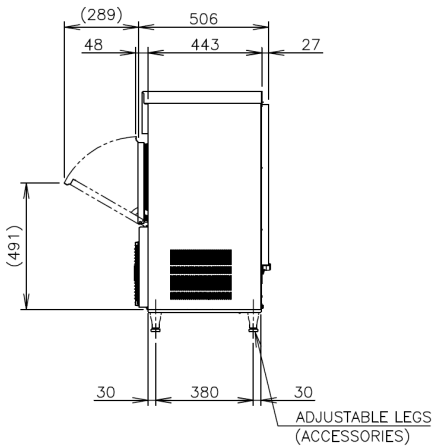
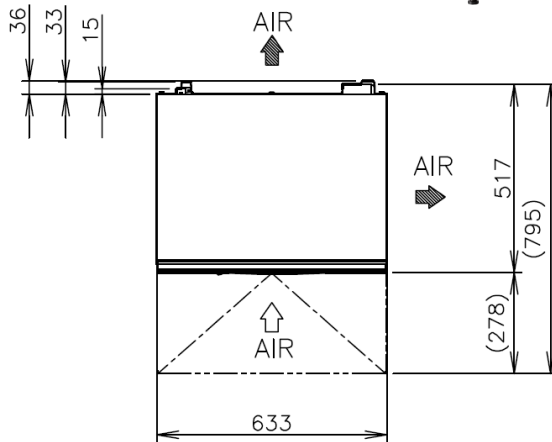
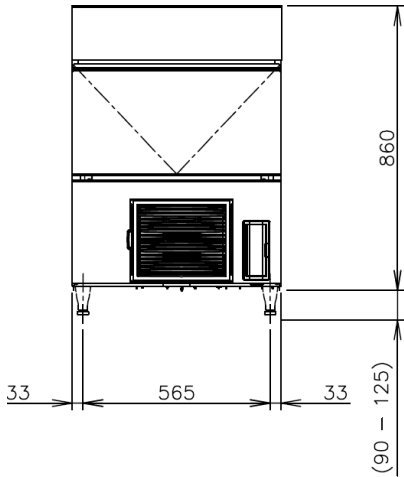

For free 6 month extended warranty, register online within 4 weeks of purchase date.

hoshizaki.com.au