



HOSHIZAKI

IM - 65PE - 28

Model Number
91000181

48KG Cube Ice Maker, Self Contained



Hoshizaki IM-65PE Cube model is a self-contained ice maker producing up to **53kg (10°C Air temp; 10°C Water)** of cube ice per 24 hours.

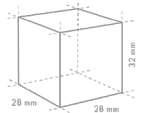

Cube Size: **STANDARD**
Weight: 23 g

- Produces compact, dry, tasteless and slow melting cube ice, allowing just the right amount of dilution.
- Automated cleaning (wash auto-restart).
- Water circuit cleaning notification.
- Condenser cleaning notification.
- Magnetic dc pump motor with variable speed.
- High grade stainless steel.
- Stand-by/wash buttons.
- Removable door gasket.
- Easy-clean air filter.

PRODUCT SPECIFICATION

Ice Type	Cube
Production Capacity per 24hours	Approx. 55kg @ 10°C Air temp; 10°C Water Approx. 48kg @ 21°C Air temp; 15°C Water Approx. 39kg @ 32°C Air temp; 21°C Water
Max Storage Capacity	Approx. 26kg (Bin Control Setting Approx. 18kg)
Dimensions	633mm (W), 506mm (D), 930mm (H) (840mm without legs)
Weight Net Packed Weight	48kg 58kg
Cooling	Air
AC Supply Voltage	1 PHASE 220-240V 50Hz/ 10 AMP Plug
Refrigerant	R290
Operating Conditions	Ambient Temp.: 1-40°C Water Supply Temp.: 5-35°C Water Supply Pressure: 0.07-0.8MPa (0.7 - 8bar) Voltage Range: Rated Voltage ±6%
Water Consumption Per 24h	Approx. 0.43m ³ @ 10°C Air temp; 10°C Water Approx. 0.12m ³ @ 21°C Air temp; 15°C Water Approx. 0.10m ³ @ 32°C Air temp; 21°C Water
Heat Rejection (AT 32°C, WT 21°C)	830W
Accessories included	Installation kit, Scoop
GEM Number	AIM0010

INSTALLATION REQUIREMENTS

- Ensure the condenser is cleaned periodically as per the manufacturer’s manual.
- Do not plug the unit into multi-plug power boards with other appliances
- Room ventilation or air conditioning can improve the situation by reducing the humidity.
- Hoshizaki recommends the use of a compatible water filter to prevent non-warrantable scale & sediment complications.

*Refer to manual for full installation & maintenance requirements.



For free 6 month extended warranty, register online within 4 weeks of purchase date.
hoshizaki.com.au



HOSHIZAKI

IM - 65PE - 28

48KG Cube Ice Maker, Self Contained

TECHNICAL DRAWING

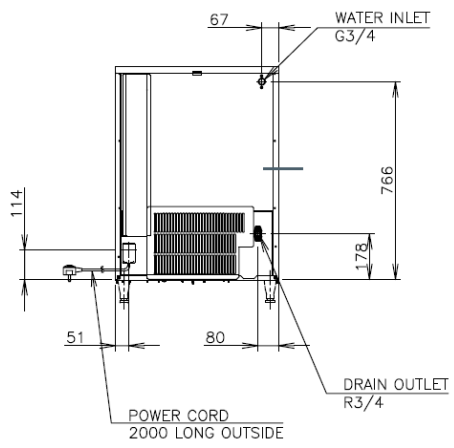
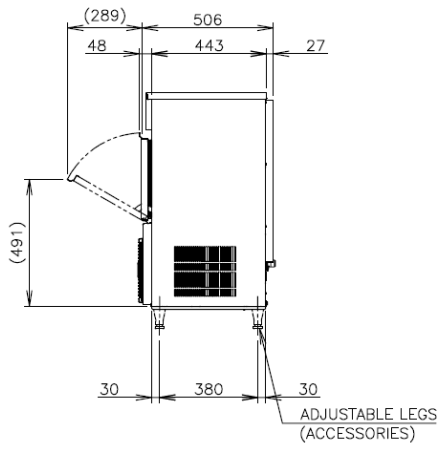
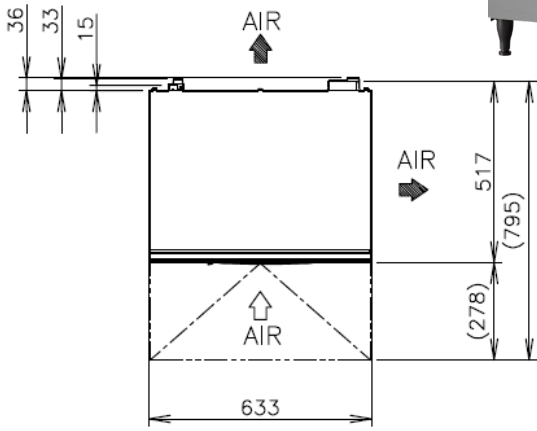
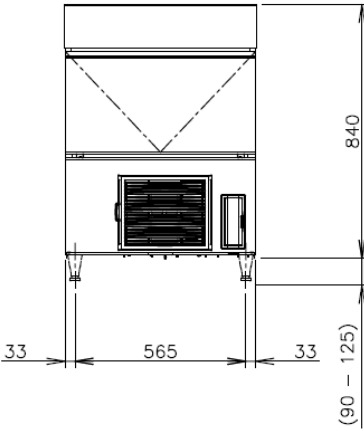

For free 6 month extended warranty, register online within 4 weeks of purchase date.

hoshizaki.com.au