



HOSHIZAKI

IM - 130PE - 23

Model Number
91000183

Cube 96kg Ice Maker - Self Contained



Hoshizaki IM-130PE-23 Cube model is a self-contained ice maker producing up to 106kg (10°C Air temp; 10°C Water) of cube ice per 24 hours.

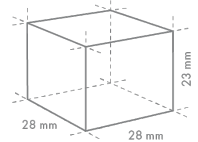

Cube Size: **M-23**
Weight: 17 g

- Produces compact, dry, tasteless and slow melting cube ice, allowing just the right amount of dilution.
- Automated cleaning (wash auto-restart).
- Water circuit cleaning notification.
- Condenser cleaning notification.
- Magnetic dc pump motor with variable speed.
- High grade stainless steel.
- Stand-by/wash buttons.
- Removable door gasket.
- Easy-clean air filter.

PRODUCT SPECIFICATION

Ice Type	Cube
Production Capacity per 24hours	Approx. 106kg @ 10°C Air temp; 10°C Water Approx. 96kg @ 21°C Air temp; 15°C Water Approx. 88kg @ 32°C Air temp; 21°C Water
Max Storage Capacity	Approx. 50kg (Bin Control Setting Approx. 28kg)
Dimensions	704mm (W), 506mm (D), 1280mm (H)
Weight Net Packed Weight	71kg 83kg
Cooling	Air
AC Supply Voltage	1 PHASE 220-240V 50Hz/ 10 AMP Plug
Refrigerant	R290
Operating Conditions	Ambient Temp.: 1-40°C Water Supply Temp.: 5-35°C Water Supply Pressure: 0.07-0.8MPa (0.7 - 8bar) Voltage Range: Rated Voltage ±6%
Water Consumption Per 24h	Approx. 0.57m ³ @ 10°C Air temp; 10°C Water Approx. 0.23m ³ @ 21°C Air temp; 15°C Water Approx. 0.21m ³ @ 32°C Air temp; 21°C Water
Heat Rejection (AT 32°C, WT 21°C)	1450W
Accessories included	Installation kit
GEM Number	AIM0006

INSTALLATION REQUIREMENTS

- Ensure the condenser is cleaned periodically as per the manufacturer's manual.
- Do not plug the unit into multi-plug power boards with other appliances
- Room ventilation or air conditioning can improve the situation by reducing the humidity.
- Hoshizaki recommends the use of a compatible water filter to prevent non-warrantable scale & sediment complications.

*Refer to manual for full installation & maintenance requirements.



For free 6 month extended warranty, register online within 4 weeks of purchase date.
hoshizaki.com.au



HOSHIZAKI

IM - 130PE - 23

Cube 96kg Ice Maker - Self Contained

TECHNICAL DRAWING

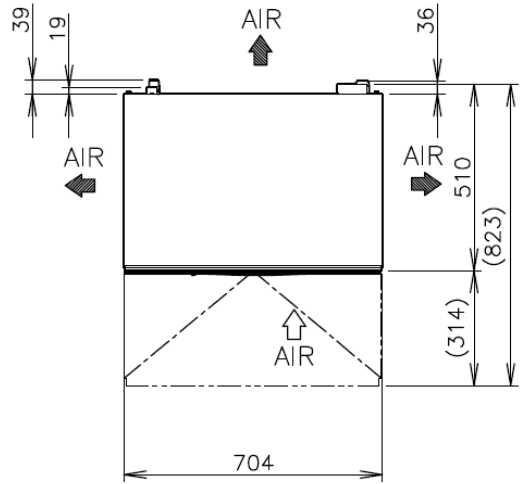
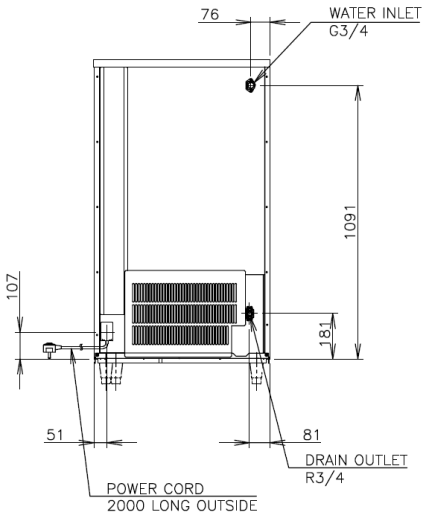
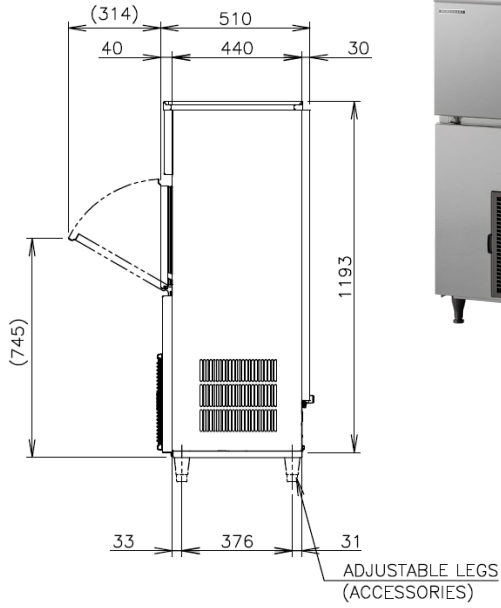
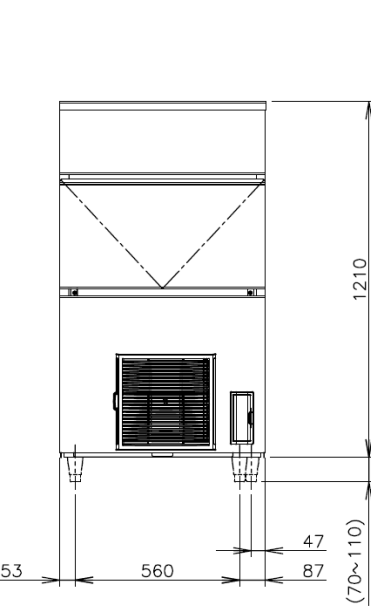

For free 6 month extended warranty, register online within 4 weeks of purchase date.

hoshizaki.com.au