



# HOSHIZAKI

## FM-300AKE-HCN-SB

Model Number  
91000183

### Nugget 210kg Ice Maker - Modular

The Hoshizaki FM-300AKE-HCN-SB is a modular nugget ice maker designed to produce up to 250kg (10°C Air temp; 10°C Water) of premium nugget ice every 24 hours.



- Ice making system with an automatic rinse cycle
- Each ice cycle is made with fresh water
- Closed water circuit for contamination protection
- Closed Cell System helps produce compact, hard and geometrically perfect ice
- Easy external access to control panel
- System comes with a magnetic DC water pump with variable speed and that has no direct coupling, which prevents any leakage
- Cleanable air filter

## PRODUCT SPECIFICATION

Ice Type	Nugget
Production Capacity per 24hours	Approx. 250kg @ 10°C Air temp; 10°C Water Approx. 210kg @ 21°C Air temp; 15°C Water Approx. 175kg @ 32°C Air temp; 21°C Water
Corresponding Bins & Top Kits	B-301SA (No Top kit)   B-501SA (8D)   B-801SA (8D + 18D)   Double Stack- B- 801SA (4DM)
Dimensions	560mm (W), 700mm (D), 780mm (H)
Weight Net   Packed Weight	81kg   88kg
Cooling	Air
AC Supply Voltage	1 PHASE 220-240V 50Hz/ 10 AMP Plug
Refrigerant	R290
Operating Conditions	Ambient Temp.: 5-40°C Water Supply Temp.: 5-35°C Water Supply Pressure: 0.05-0.8MPa (0.5 - 8bar) Voltage Range: Rated Voltage ±6%
Water Consumption Per 24h	Approx. 0.250m <sup>3</sup> @ 10°C Air temp; 10°C Water Approx. 0.210m <sup>3</sup> @ 21°C Air temp; 15°C Water Approx. 0.175m <sup>3</sup> @ 32°C Air temp; 21°C Water
Heat Rejection (AT 32°C, WT 21°C)	1840W
Accessories included	Installation kit
GEM Number	AIM0036

## INSTALLATION REQUIREMENTS

- Ensure the condenser is cleaned periodically as per the manufacturer’s manual.
- Do not plug the unit into multi-plug power boards with other appliances
- Room ventilation or air conditioning can improve the situation by reducing the humidity.
- Hoshizaki recommends the use of a compatible water filter to prevent non-warrantable scale & sediment complications.

\*Refer to manual for full installation & maintenance requirements.



For free 6 month extended warranty, register online within 4 weeks of purchase date.  
[hoshizaki.com.au](http://hoshizaki.com.au)



# HOSHIZAKI

## FM-300AKE-HCN-SB

Nugget 210kg Ice Maker - Modular

### TECHNICAL DRAWING

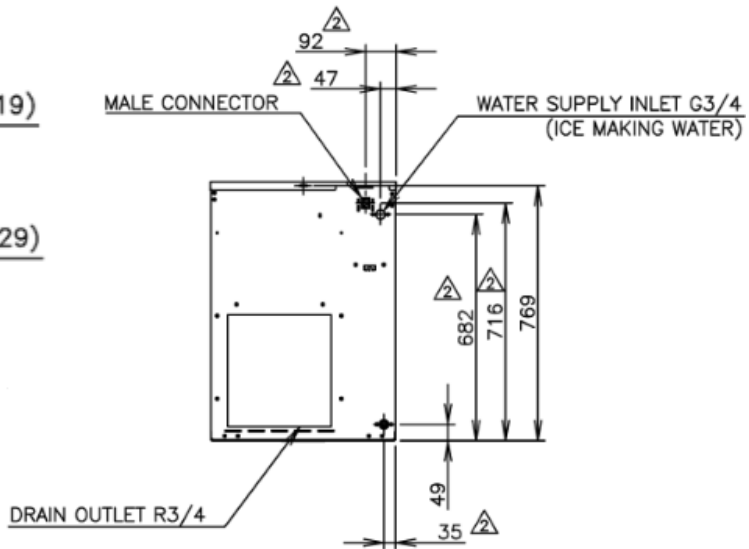
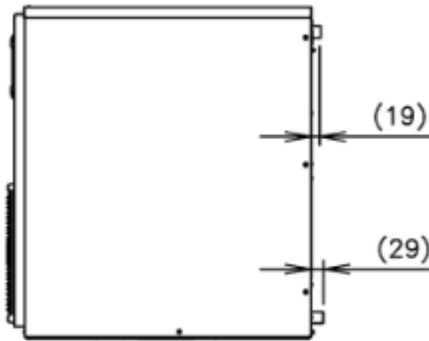
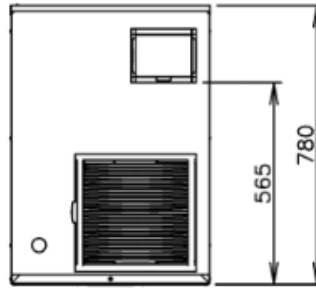
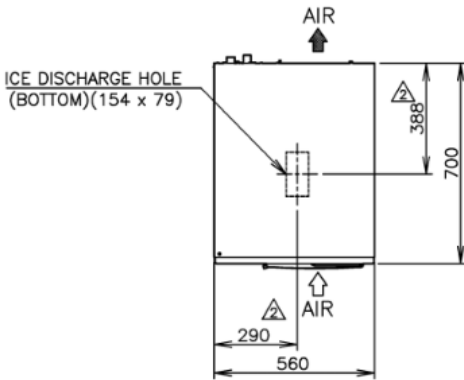

For free 6 month extended warranty, register online within 4 weeks of purchase date.  
[hoshizaki.com.au](http://hoshizaki.com.au)