



HOSHIZAKI

FM-300AKE-HC-SB

Flake 250kg Ice Maker - Modular

Model Number
91000180

The Hoshizaki FM-300AKE-HC-SB is a modular flake ice maker designed to produce up to 300kg (10°C Air temp; 10°C Water) of premium flake ice every 24 hours.



- Ice making system with an automatic rinse cycle
- Each ice cycle is made with fresh water
- Closed water circuit for contamination protection
- Closed Cell System helps produce compact, hard and geometrically perfect ice
- Easy external access to control panel
- System comes with a magnetic DC water pump with variable speed and that has no direct coupling, which prevents any leakage
- Cleanable air filter

PRODUCT SPECIFICATION

Ice Type	Flake
Production Capacity per 24hours	Approx. 300kg @ 10°C Air temp; 10°C Water Approx. 250kg @ 21°C Air temp; 15°C Water Approx. 205kg @ 32°C Air temp; 21°C Water
Corresponding Bins & Top Kits	B-301SA (No Top kit) B-501SA (8D) B-801SA (8D + 18D) Double Stack- B- 801SA (4DM)
Dimensions	560mm (W), 700mm (D), 780mm (H)
Weight Net Packed Weight	81kg 88kg
Cooling	Air
AC Supply Voltage	1 PHASE 220-240V 50Hz/ 10 AMP Plug
Refrigerant Charge	R290
Operating Conditions	Ambient Temp.: 5-40°C
	Water Supply Temp.: 5-35°C
	Water Supply Pressure: 0.05-0.8MPa (0.5 - 8bar) Voltage Range: Rated Voltage ±6%
Water Consumption Per 24h	Approx. 0.300m ³ @ 10°C Air temp; 10°C Water
	Approx. 0.250m ³ @ 21°C Air temp; 15°C Water
	Approx. 0.205m ³ @ 32°C Air temp; 21°C Water
Heat Rejection (AT 32°C, WT 21°C)	1840W
Accessories included	Installation kit
GEM Number	AIM0036

INSTALLATION REQUIREMENTS

- Ensure the condenser is cleaned periodically as per the manufacturer’s manual.
- Do not plug the unit into multi-plug power boards with other appliances
- Room ventilation or air conditioning can improve the situation by reducing the humidity.
- Hoshizaki recommends the use of a compatible water filter to prevent non-warrantable scale & sediment complications.

*Refer to manual for full installation & maintenance requirements.



For free 6 month extended warranty, register online within 4 weeks of purchase date.
hoshizaki.com.au



HOSHIZAKI

FM-300AKE-HC-SB

Flake 250kg Ice Maker - Modular

TECHNICAL DRAWING

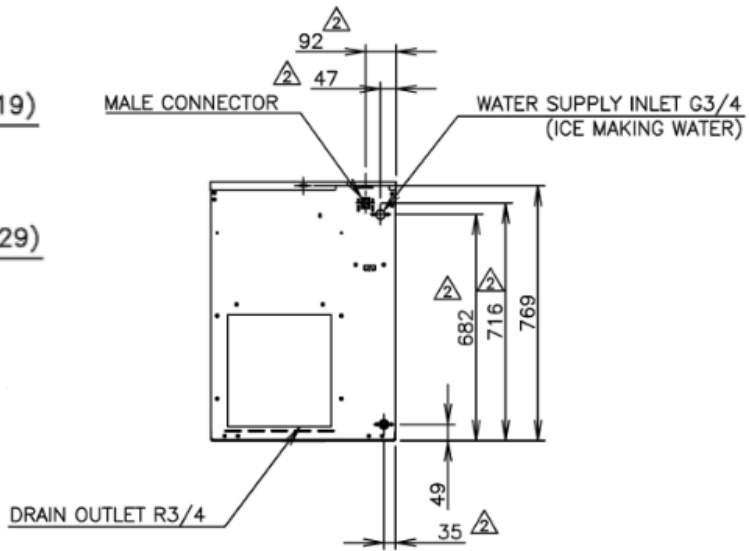
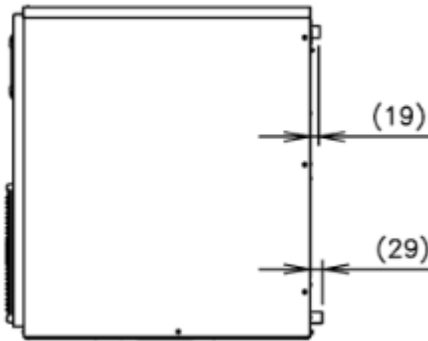
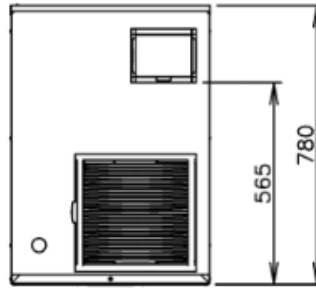
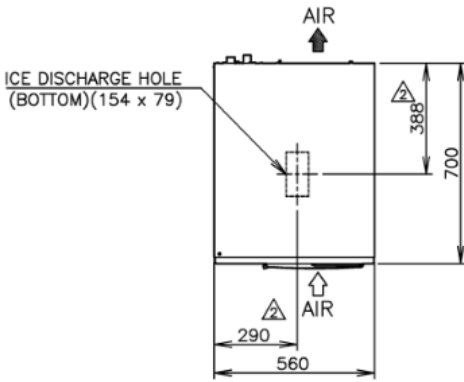

For free 6 month extended warranty, register online within 4 weeks of purchase date.
hoshizaki.com.au