



HOSHIZAKI

FM - 120KE - HC

Model Number
91000179

Flake 105kg Ice Maker - Self Contained

Hoshizaki FM-120KE-HC is a self-contained ice maker producing up to 125kg (10°C Air temp; 10°C Water) of flake ice per 24 hours.



PRODUCT SPECIFICATION

- CleanCycle6 system for rinse of built up impurities (minerals) every 6 hours
- Water consumption is equal to the ice production
- Ice making system with an automatic rinse cycle
- Closed water circuit for contamination protection
- Electronic controller
- Operation time-based parts replacement system for preventive maintenance
- Auger is made of double hardened stainless steel
- Carbon graphite bushings allows the machine to work without grease
- Cleanable air filter
- Removable door gasket

Ice Type	Flake
Production Capacity per 24hours	Approx. 125kg @ 10°C Air temp; 10°C Water Approx. 105kg @ 21°C Air temp; 15°C Water Approx. 82kg @ 32°C Air temp; 21°C Water
Max Storage Capacity	Approx. 26kg- Levelled (Bin Control Setting Approx. 21kg)
Dimensions	640mm (W), 600mm (D), 800mm (H)
Weight Net Packed Weight	66kg 76kg
Cooling	Air
AC Supply Voltage	1 PHASE 220-240V 50Hz/ 10 AMP Plug
Refrigerant	R290
Operating Conditions	Ambient Temp.: 5-40°C Water Supply Temp.: 5-35°C Water Supply Pressure: 0.05-0.8MPa Voltage Range: Rated Voltage ±6%
Water Consumption Per 24h	Approx. 0.125m ³ @ 10°C Air temp; 10°C Water Approx. 0.105m ³ @ 21°C Air temp; 15°C Water Approx. 0.082m ³ @ 32°C Air temp; 21°C Water
Heat Rejection (AT 32°C, WT 21°C)	655W
Accessories included	Installation kit, Scoop
GEM Number	AIM0023

INSTALLATION REQUIREMENTS

- Ensure the condenser is cleaned periodically as per the manufacturer's manual.
- Do not plug the unit into multi-plug power boards with other appliances
- Room ventilation or air conditioning can improve the situation by reducing the humidity.
- Hoshizaki recommends the use of a compatible water filter to prevent non-warrantable scale & sediment complications.

*Refer to manual for full installation & maintenance requirements.



For free 6 month extended warranty, register online within 4 weeks of purchase date.
hoshizaki.com.au



HOSHIZAKI

FM - 120KE - HC

Flake 105kg Ice Maker - Self Contained

TECHNICAL DRAWING

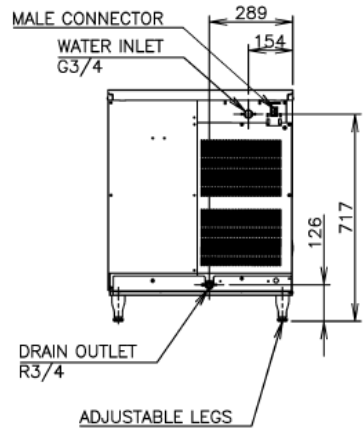
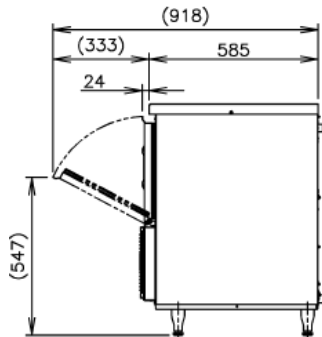
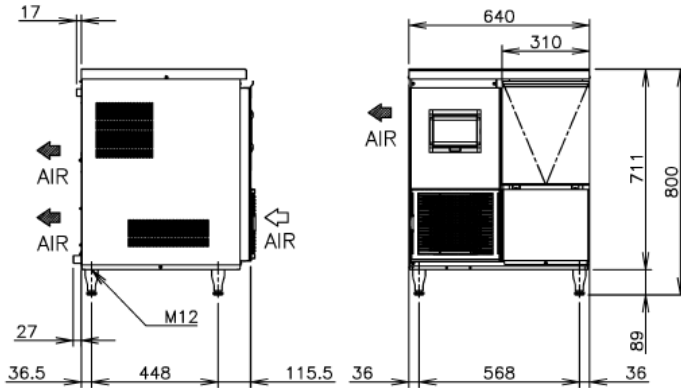
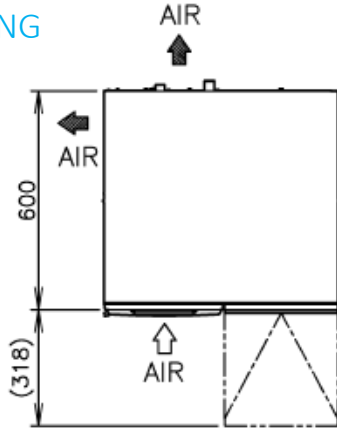

For free 6 month extended warranty, register online within 4 weeks of purchase date. hoshizaki.com.au