

NOTE: COMPONENT AND ASSEMBLY MUST BE COMPLIANT TO APPLICABLE RECENT ROHS DIRECTIVES.

REVISION SHEET NO		ZONE	CHANGE NOTE		ECN	DATE	DRAWN
			DETAILS				

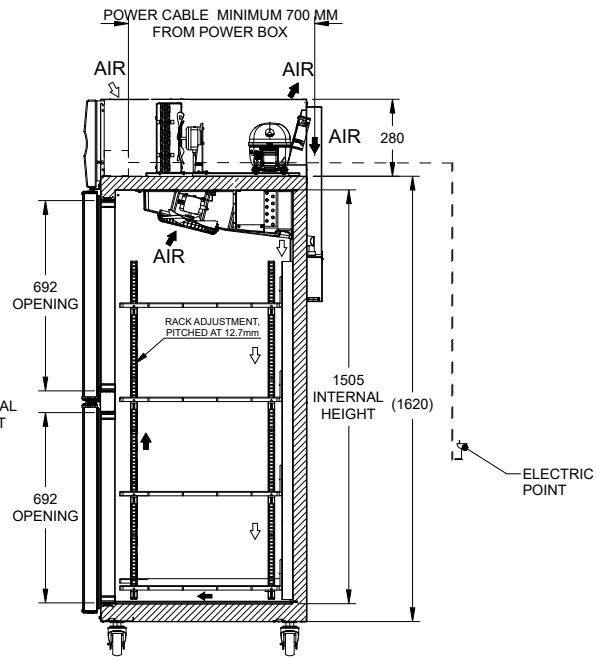
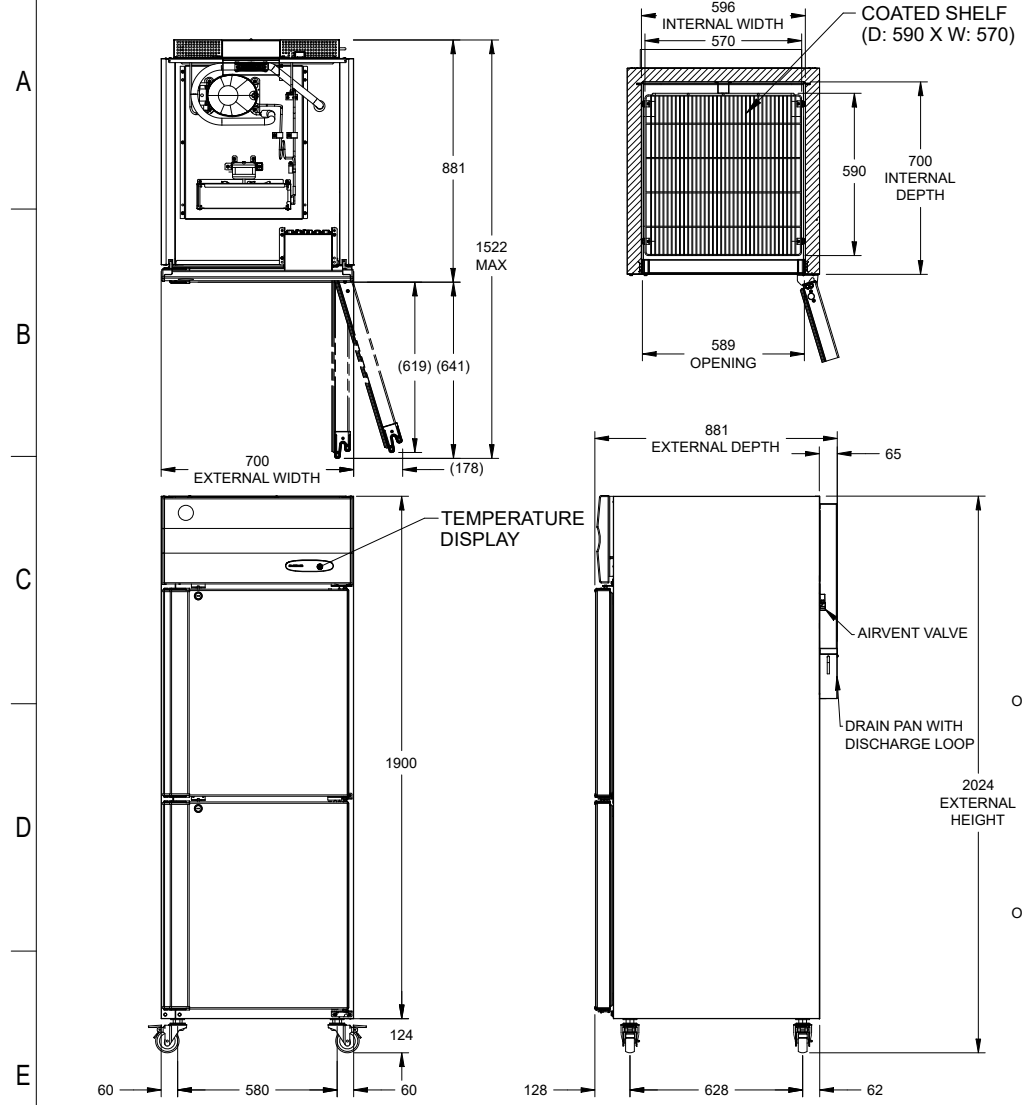

- OPTIONS:
 1. BOTTOM & REAR PANEL CAN BE AVAILABLE IN SUS 430/ SUS304
 2. ALL EXTERIOR & INTERIOR CAN BE AVAILABLE IN SUS 304 (IN THIS OPTION BOTTOM & REAR PANEL ARE PAINTED)

ITEM	HOSHIZAKI FREEZER
MODEL	HFWE77LS4
POWER SUPPLY	SINGLE PHASE, 230V AC, 50HZ
RATED CURRENT	1.8 AMPS
RATED POWER	400 W
HEAT REJECTION	887 W
POWER CORD	10 AMPS / 3 METER
EFFECTIVE CAPACITY	398 LITRE
OUTSIDE DIMENSIONS	700 (W) X 881 (D) X 2024 (H - WITH CASTOR)
INSIDE DIMENSIONS	596 (W) X 700 (D) X 1505 (H)
EXTERIOR	SS 430 HAIRLINE NO 4 FINISH, GALVANIZED STEEL POWDER COATED (BOTTOM)
INTERIOR	SS 430 HAIRLINE NO 4 FINISH
INSULATION	POLYURETHANE FOAM (CFC FREE)
INSULATION FOAM BLOWING AGENT	CYCLOPENTANE
REFRIGERATION SYSTEM	FORCED AIR CIRCULATION
DEFROST SYSTEM	IN COMPRESSOR OFF CYCLE
COMPRESSOR	HERMETIC 766 W
CONDENSER	FORCED (WIRE ON TUBE)
EVAPORATOR	FORCED (FIN & TUBE)
REFRIGERANT/ CHARGE	R-290 / 80 gram
TEMP. CONTROL	ELECTRONIC ADJUSTABLE FROM -18°C TO -22°C
DEFROST CONTROL	BY TEMPERATURE CONTROLLER
ELECTRIC CIRCUIT PROTECTION	NON RESETTABLE FUSE (GLASS FUSE) 10 AMP
COMPRESSOR PROTECTION	MOTOR PROTECTOR
CASTOR	NON ADJUSTABLE 4 NOS
SHELF	4 PCS
WEIGHT	NET:121KG (GROSS: APPROX 144KG)
PACKAGE	CARTON (WOODEN PALLET) 785MM (W) X 994MM (D) X 2090MM(H)
ACCESSORIES	SHELF CLIPS & SLELVES
OPERATING CONDITIONS	AMBIENT TEMPERATURE : 10 TO 43°C VOLTAGE RANGE RATED VOLTAGE ±6%
CABINET LAMP (FOR LS4 VERSION)	C-TYPE 510MM, 2W, DC24V
LAMP DRIVER (FOR LS4 VERSION)	ELECTRONIC DRIVER 20W

*WE RESERVE THE RIGHT TO MAKE CHANGES IN SPECIFICATIONS AND DESIGN WITHOUT PRIOR NOTICE

- INSTALL THE PRODUCT PROPERLY IN ACCORDANCE WITH THE INSTRUCTIONS ON LOCATION, ELECTRICAL CONNECTIONS STATED IN THE INSTRUCTION MANUAL PROVIDED. ALLOW 10MM EXTRA SPACE AT THE INSTALLATION SITE TO MEET ANY INSTALLATION REQUIREMENTS (ADDITIONAL SPACING IS ALSO REQUIRED FOR PROPER AIR FLOW AND PIPE CONNECTIONS).
- THE HEAT REJECTION IS BASED ON THE REACHED PULL DOWN TEMPERATURE AT AMBIENT TEMPERATURE OF 43°C AND POWER SUPPLY OF 230VAC 50HZ. THE AMPERAGE AND ELECTRIC CONSUMPTION ARE BASED ON MEASUREMENT AT AMBIENT TEMPERATURE OF 43°C AND POWER SUPPLY OF 230VAC 50HZ.

THIS ASSEMBLY DRAWING IS FOR ILLUSTRATION PURPOSE. COMPONENTS, ASSEMBLY SEQUENCE MAY VARY DEPENDING UPON MANUFACTURING PRACTICES SPECIFIC TO MANUFACTURING LOCATIONS. REFER PROCESS WORK INSTRUCTIONS FOR MORE DETAILS ON ASSEMBLY. REFER SAP BOM FOR EXACT MATERIAL CONSUMPTION.

UNSPECIFIED TOLERANCES						SCALE: NTS	TITLE		DWG. NO:	REVISION	
DIM	<6	6-30	30-120	120-400	400-1000	>1000	ALL DIMENSIONS ARE IN MM	REACH-IN REFRIGERATOR		0712745	A
TOL	±0.1	±0.2	±0.3	±0.5	±0.8	±1.2				SAP CODE	
UNSPECIFIED TOL. ON ANGLE ±0.5						DRAWN BY		MODEL			
						PUSHPENDRA		HFWE77LS4			
						CHECKED BY		RELEASE DATE	SHEET		
						KIRAN		20.11.2024	1 OF 1		
REFERENCE STANDARD						APPROVED BY		RELEASE STAGE:			
						PRATAP		RELEASED			