

WRU/PDC/15  
 REV/A  
 DATE 01.03.2022  
 THIS DRAWING AND THE INFORMATION CONTAINED HEREIN IS PROPRIETARY TO M/S WESTERN REFRIGERATION PVT. LTD. IT SHALL NOT BE REPRODUCED, COPIED OR DISCLOSED, IN WHOLE OR IN PART OR USED FOR MANUFACTURE OR FOR OTHER PURPOSE WITHOUT THE WRITTEN PERMISSION OF M/S WESTERN REFRIGERATION PVT. LTD.

NOTE: COMPONENT AND ASSEMBLY MUST BE COMPLIANT TO APPLICABLE RECENT ROHS DIRECTIVES.

REVISION SHEET NO		ZONE	CHANGE NOTE		
DETAILS		ECN	DATE	DRAWN	

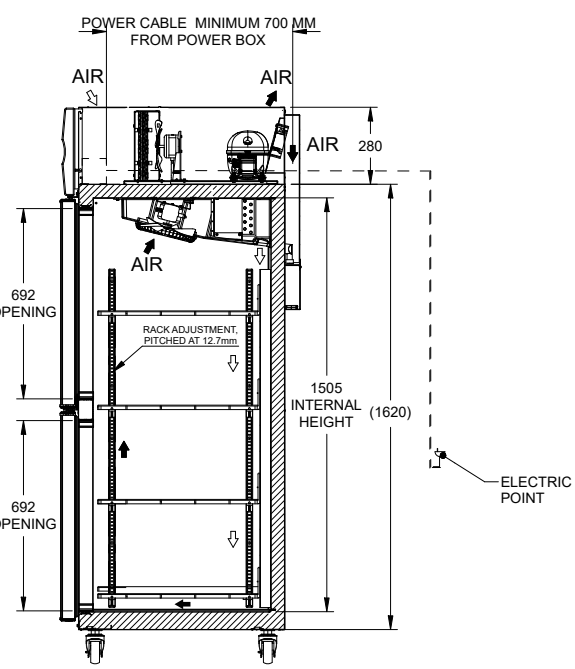
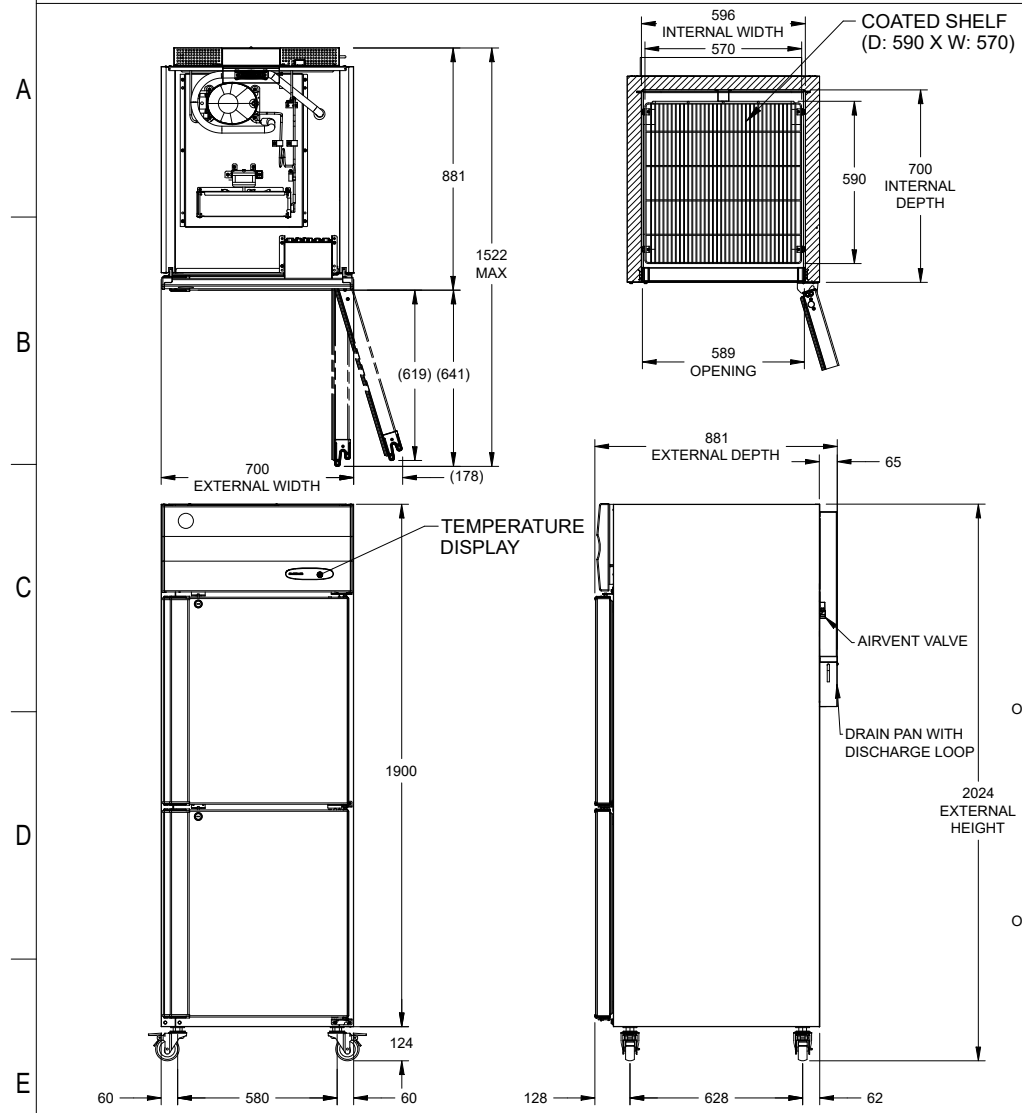

- OPTIONS:
- BOTTOM & REAR PANEL CAN BE AVAILABLE IN SUS 430/ SUS304
  - ALL EXTERIOR & INTERIOR CAN BE AVAILABLE IN SUS 304 (IN THIS OPTION BOTTOM & REAR PANEL ARE PAINTED)

ITEM	HOSHIZAKI REFRIGERATOR
MODEL	HRWE77LS4
POWER SUPPLY	SINGLE PHASE, 230V AC, 50HZ
RATED CURRENT	1.3 AMPS
RATED POWER	280 W
HEAT REJECTION	785 W
POWER CORD	10 AMPS / 3 METER
EFFECTIVE CAPACITY	398 LITRE
OUTSIDE DIMENSIONS	700 (W) X 881 (D) X 2024 (H - WITH CASTOR)
INSIDE DIMENSIONS	596 (W) X 700 (D) X 1505 (H)
EXTERIOR	SS 430 HAIRLINE NO 4 FINISH, GALVANIZED STEEL POWDER COATED (BOTTOM)
INTERIOR	SS 430 HAIRLINE NO 4 FINISH
INSULATION	POLYURETHANE FOAM (CFC FREE)
INSULATION FOAM BLOWING AGENT	CYCLOPENTANE
REFRIGERATION SYSTEM	FORCED AIR CIRCULATION
DEFROST STSTEM	IN COMPRESSOR OFF CYCLE
COMPRESSOR	HERMETIC 305 W
CONDENSER	FORCED (WIRE ON TUBE)
EVAPORATOR	FORCED (FIN & TUBE)
REFRIGERANT/ CHARGE	R-290 / 74 gram
TEMP. CONTROL	ELECTRONIC ADJUSTABLE REFRIGERATOR: 1°C TO 4°C
DEFROST CONTROL	BY TEMPERATURE CONTROLLER
ELECTRIC CIRCUIT PROTECTION	NON RESETTABLE FUSE (GLASS FUSE) 10 AMP
COMPRESSOR PROTECTION	MOTOR PROTECTOR
CASTOR	NON ADJUSTABLE 4 NOS
SHELF	4 PCS
WEIGHT	NET: 113KG (GROSS: APPROX 136KG)
PACKAGE	CARTON (WOODEN PALLET) 785MM (W) X 994MM (D) X 2090MM(H)
ASSESSORIES	SHELF CLIPS & SLELVES
OPERATING CONDITIONS	AMBIENT TEMPERATURE : 5 - 43°C VOLTAGE RANGE RATED VOLTAGE ±6%
CABINET LAMP (FOR LS4 VERSION)	C-TYPE 510MM, 2W, DC24V
LAMP DRIVER (FOR LS4 VERSION)	ELECTRONIC DRIVER 20W

\*WE RESERVE THE RIGHT TO MAKE CHANGES IN SPECIFICATIONS AND DESIGN WITHOUT PRIOR NOTICE

- INSTALL THE PRODUCT PROPERLY IN ACCORDANCE WITH THE INSTRUCTIONS ON LOCATION, ELECTRICAL CONNECTIONS STATED IN THE INSTRUCTION MANUAL PROVIDED. ALLOW 10MM EXTRA SPACE AT THE INSTALLATION SITE TO MEET ANY INSTALLATION REQUIREMENTS (ADDITIONAL SPACING IS ALSO REQUIRED FOR PROPER AIR FLOW AND PIPE CONNECTIONS).
- THE HEAT REJECTION IS BASED ON THE REACHED PULL DOWN TEMPERATURE AT AMBIENT TEMPERATURE OF 43°C AND POWER SUPPLY OF 230VAC 50HZ. THE AMPERAGE AND ELECTRIC CONSUMPTION ARE BASED ON MEASUREMENT AT AMBIENT TEMPERATURE OF 43°C AND POWER SUPPLY OF 230VAC 50HZ.

THIS ASSEMBLY DRAWING IS FOR ILLUSTRATION PURPOSE. COMPONENTS, ASSEMBLY SEQUENCE MAY VARY DEPENDING UPON MANUFACTURING PRACTICES SPECIFIC TO MANUFACTURING LOCATIONS. REFER PROCESS WORK INSTRUCTIONS FOR MORE DETAILS ON ASSEMBLY. REFER SAP BOM FOR EXACT MATERIAL CONSUMPTION.

UNSPECIFIED TOLERANCES						
DIM	<6	6-30	30-120	120-400	400-1000	>1000
TOL	±0.1	±0.2	±0.3	±0.5	±0.8	±1.2
UNSPECIFIED TOL. ON ANGLE ±0.5						

SCALE: NTS	 ALL DIMENSIONS ARE IN MM
DRAWN BY	
KIRAN	
CHECKED BY	PRATAP
APPROVED BY	PRATAP

TITLE	REACH-IN REFRIGERATOR	
MODEL	HRWE77LS4	
RELEASE DATE	25.07.2024	SHEET 1 OF 1
RELEASE STAGE:	RELEASED	

DWG. NO:	0712732	REVISION	A
SAP CODE	--		