

- Relative humidity exceeding 60% may result in excessive condensation on the exterior.
- The food temperature is controllable by turning over the food mounts.
- Product Code: S056-C174

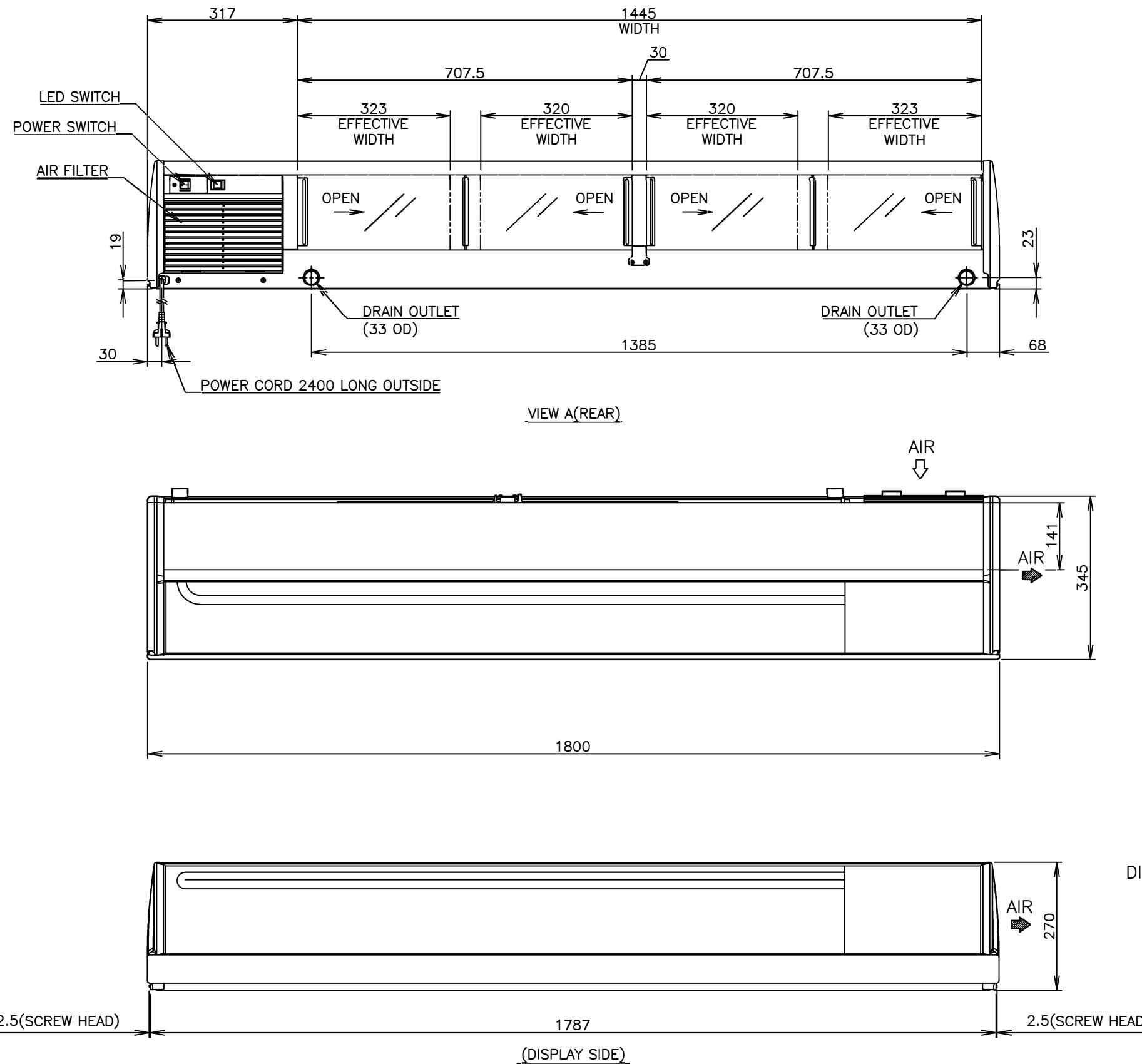

ITEM	Hoshizaki Counter Showcase	
MODEL	HNC-180BE-R-BLH	
POWER SUPPLY	1 Phase 220-240V 50Hz Capacity: 0.39kVA (1.63A)	
AMPERAGE	Rated: 1.0A Starting: 6A	
ELECTRIC CONSUMPTION	150W (Power Factor: 62%)	
HEAT REJECTION	420W	
PULL DOWN TIME (10°C)	Approx. 30min. (Ambient Temp. 30°C, No Load)	Measured 20 mm above the food mount (normal position) located at the interior bottom center
SATURATION TEMPERATURE	Approx. 5°C (Ambient Temp. 30°C, No Load)	
POWER CORD	2.4m	
EFFECTIVE CAPACITY	72L	
OUTSIDE DIMENSIONS	1800mm(W) × 345mm(D) × 270mm(H)	
INSIDE DIMENSIONS	1445mm(W) × 288mm(D)[Floor] × 157mm(H)	
EXTERIOR	Clear Glass, ABS Plastic, PVC Plastic	
INTERIOR	Clear Glass, ABS Plastic, Stainless Steel	
INSULATION	Polyurethane Foam	
INSULATION FOAM BLOWING AGENT	HFO-1233zd(E)	
DOOR	Sliding Glass × 4 [363mm(W) × 172mm(H)]	
REFRIGERATION SYSTEM	Convection Cooling	
DEFROST SYSTEM	N/A	
COMPRESSOR	Hermetic 110W	
CONDENSER	Fin and Tube type, Cooling Fan Motor provided	
EVAPORATOR	(Upper) Tube Type, (Lower) Pipe on Sheet Type	
REFRIGERANT	R600a/46g	
ELECTRIC CIRCUIT PROTECTION	Earth Leakage Circuit Breaker (with Overcurrent Protector) 15A Earth Wire	
REFRIGERANT CIRCUIT PROTECTION	Motor Protector	
LIGHTING	LED	
WEIGHT	42kg (Gross: 60kg)	
PACKAGE	Carton (Wooden Pallet) 1880mm(W) × 415mm(D) × 517mm(H)	
ACCESSORIES	Food Mount × 5, Joint × 2, Drain Hose × 1	
OPERATING CONDITIONS	Ambient Temperature: 10 - 30°C Voltage Range: Rated Voltage ±6%	

*We reserve the right to make changes in specifications and design without prior notice.

- Install the product properly in accordance with the instructions on location, water supply/drain connections and electrical connections stated in the instruction manual provided. Allow 10mm extra space at the installation site to meet any installation requirements (additional spacing is also required for proper air flow and pipe connections).

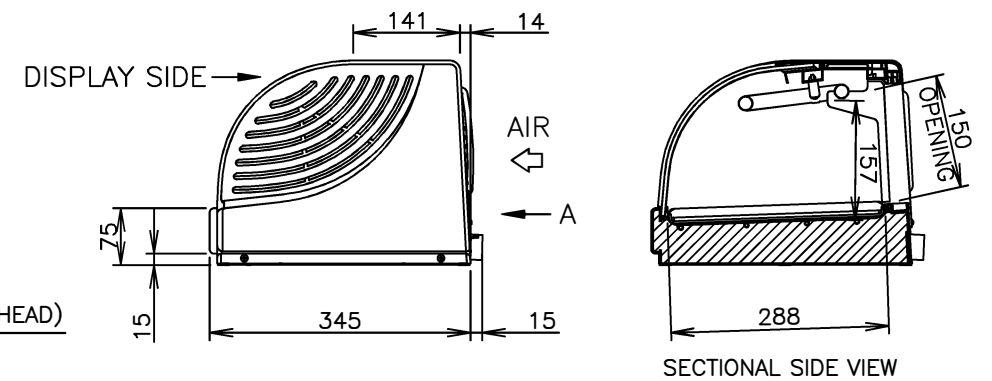

HOSHIZAKI COUNTER SHOWCASE HNC-180BE-R-BLH

APPROVED YAMASAKI	CHECKED YORITA	DESIGNED HIROSAWA	DRAWN UEDA	SCALE 1/10	TRIGONOMETRY
*	*	△	****	DATE 2021.02.26	DRAWING NO. D30020
APPROVED	DESIGNED	SYMBOL	DATE		SYMBOL