



SELF-CONTAINED CUBER

PARTS LIST

[HE] [GRAM] [KOREA] [HS]

E1FC

E1FC-D001, D002, D003, D004, D005, D020, D200

A-1 NOV. 2011
B-0 JAN. 2012
B-1 OCT. 2012
C-0 JAN. 2013
D-0 JAN. 2014
E-0 JAN. 2015
E-1 APR. 2015
F-0 JAN. 2016
G-0 JAN. 2017
G-1 MAY. 2017
G-2 AUG. 2017
G-3 NOV. 2017
J-1 JUL, 2019
J-2 SEP, 2019

IM-45CNE
IM-45CNE-25
IM-45CNE(G60)
IM-45CNE(KR)
IM-45CNE(HS)
IM-45CNE-25(HS)
IM-45CNE-SN

List of Specifications

IM-45CNE	E1FC	Standard
IM-45CNE-25	E1FC-D001	25mm ICE of IM-45CNE
IM-45CNE(G60)	E1FC-D002	60Hz
IM-45CNE(KR)	E1FC-D003	For KOREA power cord: hard-wired type
IM-45CNE(HS)	E1FC-D004	For Singapore special water valve
IM-45CNE-25(HS)	E1FC-D005	25mm ICE for Singapore special water valve
IM-45CNE	E1FC-D020	For GRAM
IM-45CNE-SN	E1FC-D200	Integrated in E1FC.

Auxiliary Codes

Auxiliary Code Breakdown

The auxiliary code is the first two characters in the serial number. The first character indicates the year. Years progress or regress in alphabetical order. The series runs from "A" through "V" and the letters "I" and "O" are skipped. The second character indicates significant part changes within a year. Base is "0" and this number advances for each change. In cases where there is a letter in parentheses, this designates the month. This is the last character in the serial number. The series runs from "(A)" through "(M)" and the letter "(I)" is skipped. This designation is only included when identifying a parts change within an auxiliary code.

Note About Ordering Parts

Most assemblies cannot be ordered as complete units; parts in the assemblies generally must be ordered separately.

MARKS LOCATED UNDER THE AUXILIARY CODE

- = Part deleted.

FASTENER PART NUMBER

SCREWS

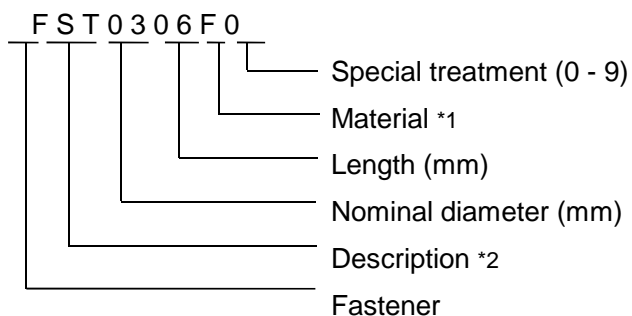

*1

F: Steel
S: Austenitic stainless steel
M: Martensitic stainless steel
B: Copper alloy
P: Polycarbonate
N: Polyamide
V: PVC
A: ABS
X: Polyacetal
L: Aluminum

NUTS & WASHERS

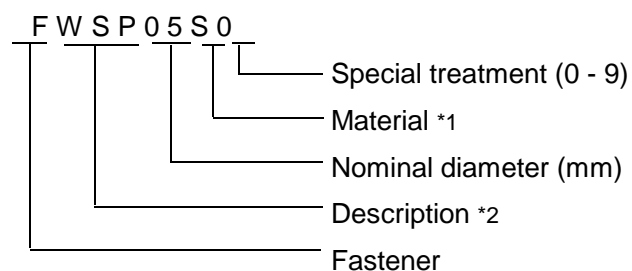

*2

First letter
S: Machine screw
T: Tapping screw
M: Wood screw
B: Bolt
W: Washer
N: Nut

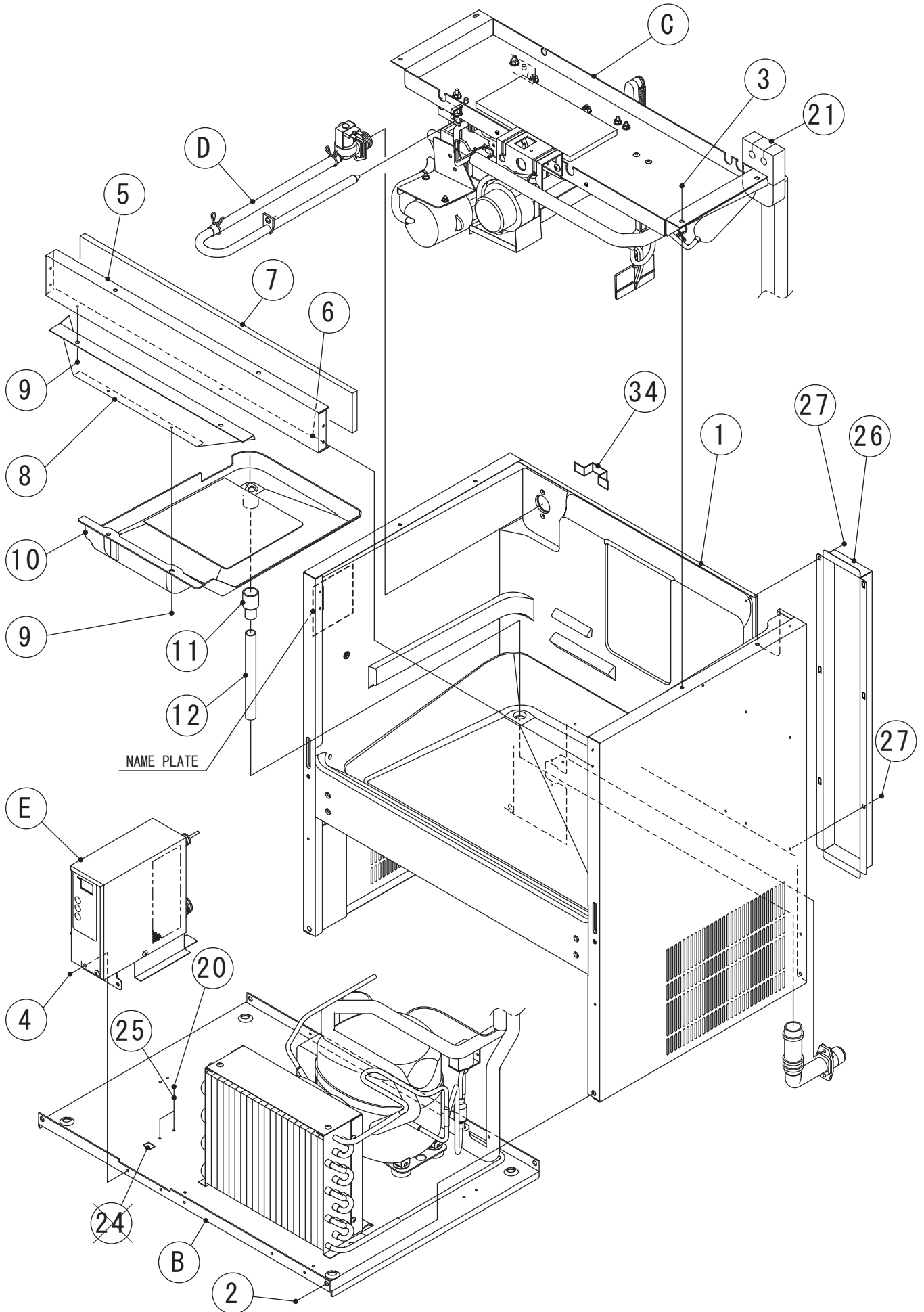

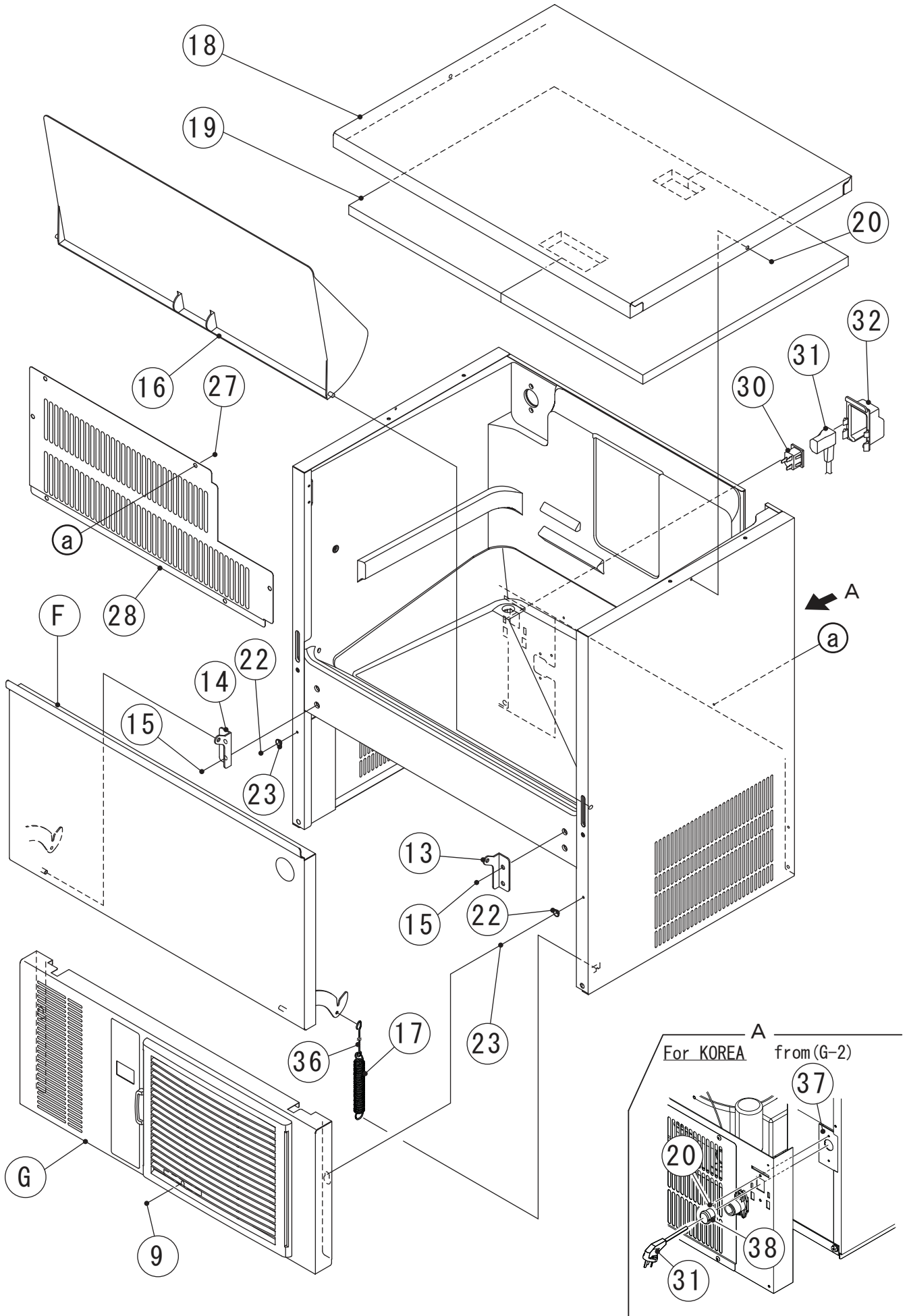

HE,GRAM,HS

MODEL: IM-45CNE,IM-45CNE-25			TITLE: A.ICE CUBER ASSY					
INDEX NO.	DESCRIPTION	MATERIAL OR MODEL NUMBER	PART NUMBER	REQ'D NUMBER				
				A-1 B-0	B-1,C-0 D-0	D-1 E-0	E-1 G-0	G-1
B	REFRIGERATION ASSY		1H4827A01	1	1	1	1	1
C	ICE MAKING MECHANISM ASSY		1H4828A01	1	1	1	-	-
			1H4828A02	-	-	-	1	1
D	WATER CIRCUIT ASSY		3Y5610A02	1	1	1	1	1
E	CONTROL BOX ASSY		2X0439A01	1	-	-	-	-
			2X1218A01	-	1	1	1	1
F	DOOR ASSY		3Y5644A01	1	1	1	1	1
G	FRONT PANEL		3Y5645G01	1	1	1	1	1
1	UNIT FRAME		1H4826G01	1	1	1	1	1
2	TAPPING SCREW - HEX		442040-01	4	4	4	4	4
3	TRUSS HEAD MACHINE SCREW		FST0412S0	4	4	4	4	4
4	FLANGE BOLT (C-TITE)		FTR0408M0	2	2	2	2	2
5	FRONT FRAME		3X6086-02	1	1	1	1	1
6	RIVET	SSD42SSBS(t1.6~3.2)	7170-0002	4	4	4	4	4
7	INSULATION - FRONT FRAME		4Y1924-01	1	1	1	1	1
8	FRONT FRAME(LO)		2H4624-01	1	1	1	1	1
9	TRUSS HEAD TAPPING SCREW (S-TITE)		FTS0408M0	5	5	5	5	5
10	DRAIN PAN		2H1440-01	1	1	1	1	1
11	DRAIN TUBE		4Z0986R01	1	1	1	1	1
12	DRAIN PIPE		4Y7493P04	1	1	1	1	1
13	HINGE (RIGHT)		4H2583-01	1	1	1	1	1
14	HINGE (LEFT)		4H2584-01	1	1	1	1	1
15	HEX HEAD BOLT (SPRING WASHER AND FLAT WASHER)		FBK0620S0	4	4	4	4	4
16	SLOPE		2H1349-02	1	1	1	1	1
17	SPRING		4Y9336M01	1	1	1	1	1
18	TOP PANEL		2X0652M01	1	1	1	1	1
19	INSULATION - TOP	(50Hz)	3Y5961P01	1	1	1	-	-
			3Y5961P02	-	-	-	1	1
		(60Hz)	3Y5961P01	1	1	1	1	-
			3Y5961P02	-	-	-	-	1
20	TRUSS HEAD MACHINE SCREW		FST0408S0	4	4	4	4	4
21	INSULATION - BIN		4Y7416P01	1	1	1	1	1
22	TAPER COLLAR		4H0171-01	2	2	2	2	2
23	RIVET	SSD42SSBS	7170-0002	2	2	2	2	2

HE,GRAM,KOREA,HS

MODEL: IM-45CNE,IM-45CNE-25			TITLE: A.ICE CUBER ASSY					
INDEX NO.	DESCRIPTION	MATERIAL OR MODEL NUMBER	PART NUMBER	REQ'D NUMBER				
				G-2	G-3 J-0	J-1	J-2	
B	REFRIGERATION ASSY	(IM-45CNE)	1H4827A01	1	-	-	-	
			1H5999A01	-	1	1	1	
		(IM-45CNE-25)	1H4827A01	1	1	1	-	
			1H5999A01	-	-	-	1	
C	ICE MAKING MECHANISM ASSY		1H4828A02	1	1	1	1	
D	WATER CIRCUIT ASSY		3Y5610A02	1	1	1	1	
E	CONTROL BOX ASSY	(IM-45CNE)	2X1218A01	1	-	-	-	
			2X3406A01	-	1	-	-	
			2X3406A03	-	-	1	1	
		(IM-45CNE-25)	2X1218A01	1	1	-	-	
			2X1218A03	-	-	1	-	
			2X3406A03	-	-	-	1	
F	DOOR ASSY		3Y5644A01	1	1	1	1	
G	FRONT PANEL		3Y5645G01	1	1	1	1	
1	UNIT FRAME		1H4826G01	1	1	1	1	
2	TAPPING SCREW - HEX		442040-01	4	4	4	4	
3	TRUSS HEAD MACHINE SCREW		FST0410S0	4	4	4	4	
4	FLANGE BOLT (C-TITE)		FTR0408M0	2	2	2	2	
5	FRONT FRAME		3X6086-02	1	1	1	1	
6	RIVET	SSD42SSBS(t1.6~3.2)	7170-0002	4	4	4	4	
7	INSULATION - FRONT FRAME		4Y1924-01	1	1	1	1	
8	FRONT FRAME(LO)		2H4624-01	1	1	1	1	
9	TRUSS HEAD TAPPING SCREW (S-TITE)		FTS0408M0	5	5	5	5	
10	DRAIN PAN		2H1440-01	1	1	1	1	
11	DRAIN TUBE		4Z0986R01	1	1	1	1	
12	DRAIN PIPE		4Y7493P04	1	1	1	1	
13	HINGE (RIGHT)		4H2583-01	1	1	1	1	
14	HINGE (LEFT)		4H2584-01	1	1	1	1	
15	HEX HEAD BOLT (SPRING WASHER AND FLAT WASHER)		FBK0620S0	4	4	4	4	
16	SLOPE		2H1349-02	1	1	1	1	
17	SPRING		4Y9336M01	1	1	1	1	
18	TOP PANEL		2X0652M01	1	1	1	1	
19	INSULATION - TOP	(50Hz)	3Y5961P02	1	1	1	1	
		(60Hz)	3Y5961P02	1	1	1	1	

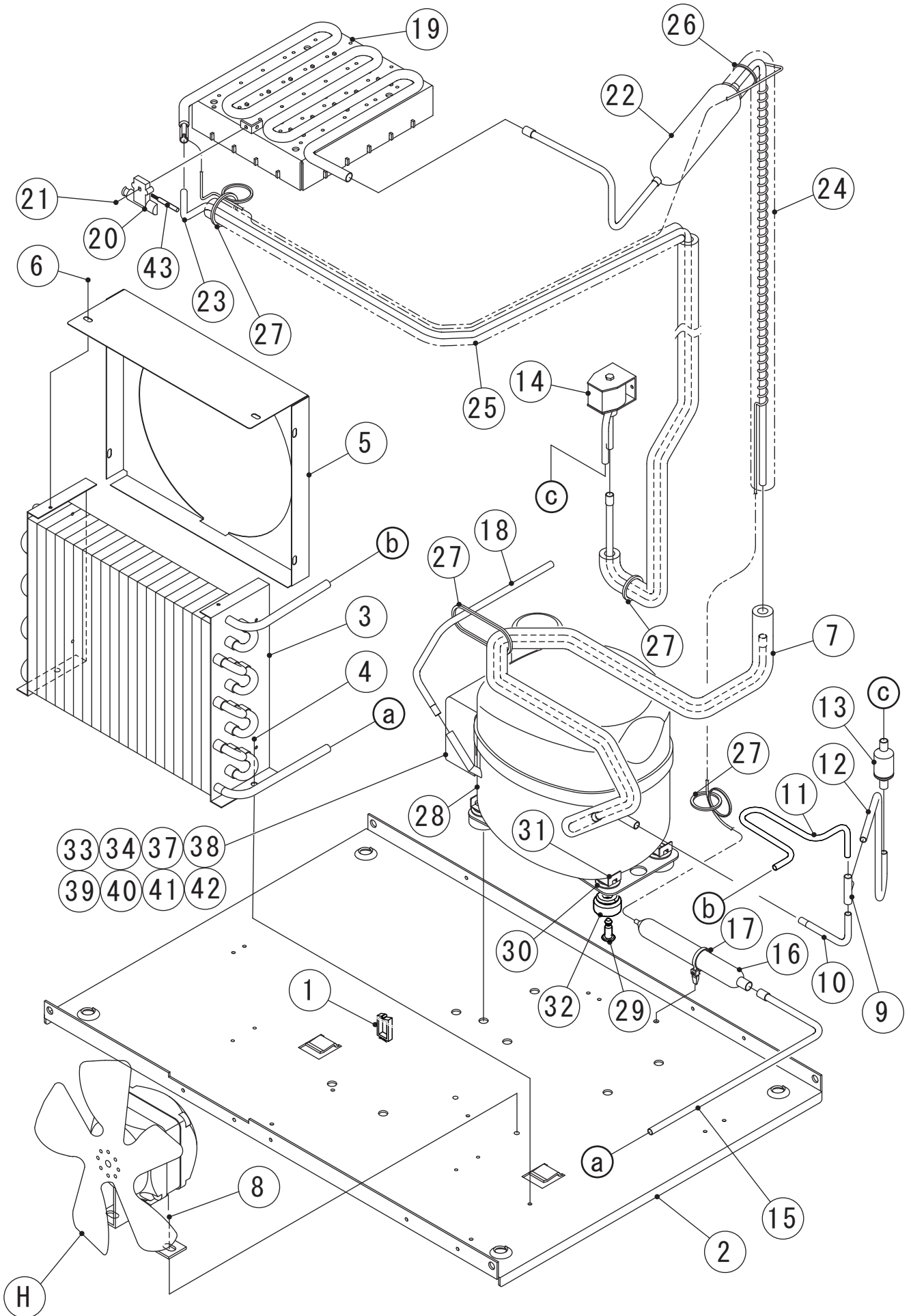

HE,GRAM,HS

MODEL: IM-45CNE,IM-45CNE-25			TITLE: B.REFRIGERATION ASSY					
INDEX NO.	DESCRIPTION	MATERIAL OR MODEL NUMBER	PART NUMBER	REQ'D NUMBER				
				A-1 B-0	B-1,C-0 D-0	D-1 E-0	E-1 G-0	G-1
H	FAN MOTOR ASSY		3E0059A01	1	1	1	1	1
1	WIRE SADDLE		428060-02	1	1	1	1	1
2	BASE		1H4829M01	1	1	1	1	1
3	CONDENCER		P03372-01	1	1	1	1	1
4	FLANGE BOLT (C-TITE)		FTR0408M0	2	2	2	2	2
5	SHROUD		3Y5606M01	1	1	1	1	1
6	TRUSS HEAD TAPPING SCREW T2		FT20408F0	6	6	6	6	6
7	PIPE(A) - LOW SIDE		3Y5607G01	1	1	1	1	1
8	HEX HEAD BOLT (SPRING WASHER AND FLAT WASHER)		FBK0612F0	2	2	2	2	2
9	TEE		417394-01	1	1	1	1	1
10	PIPE(A) - HIGH SIDE		4Y7160M01	1	1	1	1	1
11	PIPE(B) - HIGH SIDE		4Y7161M01	1	1	1	1	1
12	PIPE(A) - HOT		4Y7162M01	1	1	1	1	1
13	STRAINER		P00008-01	1	1	1	1	1
14	HOT GAS VALVE		P02539-01	1	1	1	1	1
15	PIPE(C) - HIGH SIDE		4Y7163M01	1	1	1	1	1
16	DRIER		P03584-01	1	1	1	1	1
17	TIE		P05042-01	2	2	2	2	2
18	PROSESS PIPE		4Y7164M01	1	1	1	1	1
19	EVAPORATOR	(IM-45CNE)	3H5611G02	1	1	1	1	1
		(IM-45CNE-25)	3H3941G01	1	1	1	1	1
20	HOLDER - THERMISTOR		315479-01	1	1	1	1	1
21	TRUSS HEAD TAPPING SCREW (S-TITE)		FTS0408M0	1	1	1	1	1
22	HEAT EXCHANGER		4X5640G01	1	1	1	1	1
23	PIPE(B) - HOT		3Y5859G01	1	1	1	1	1
24	Insulation Tube - FSA		H81323450	1	1	1	1	1
25	Insulation Tube (Food Sanitation Law)		H81020650	1	1	1	1	1
26	NYLON TIE	CV-100	7920-0002	1	1	1	1	1
27	NYLON TIE	CV-100	7920-0002	4	4	4	4	4
28	COMPRESSOR	(50Hz)	P02286-01	1	1	1	1	1
		(60Hz)	P02617-01	1	1	1	1	1
29	PIN		P02605-01	4	4	4	4	4
30	WASHER		P02606-01	4	4	4	4	4
31	CLAMP		P02607-01	4	4	4	4	4
32	RUBBER GROMMET		P02608-01	4	4	4	4	4

HE,GRAM,KOREA,HS

MODEL: IM-45CNE,IM-45CNE-25				TITLE: B.REFRIGERATION ASSY				
INDEX NO.	DESCRIPTION	MATERIAL OR MODEL NUMBER	PART NUMBER	REQ'D NUMBER				
				G-2	G-3 J-0	J-1	J-2	
H	FAN MOTOR ASSY		3E0059A01	1	1	1	1	
1	WIRE SADDLE		428060-02	1	1	1	1	
2	BASE		1H4829M01	1	1	1	1	
3	CONDENCER		P03372-01	1	1	1	1	
4	FLANGE BOLT (C-TITE)		FTR0408M0	2	2	2	2	
5	SHROUD		3Y5606M01	1	1	1	1	
6	TRUSS HEAD TAPPING SCREW T2		FT20408F0	6	6	6	6	
7	PIPE(A) - LOW SIDE		3Y5607G01	1	1	1	1	
8	HEX HEAD BOLT (SPRING WASHER AND FLAT WASHER)		FBK0612F0	2	2	2	2	
9	TEE		417394-01	1	1	1	1	
10	PIPE(A) - HIGH SIDE		4Y7160M01	1	1	1	1	
11	PIPE(B) - HIGH SIDE		4Y7161M01	1	1	1	1	
12	PIPE(A) - HOT		4Y7162M01	1	1	1	1	
13	STRAINER		P00008-01	1	1	1	1	
14	HOT GAS VALVE		P02539-01	1	1	1	1	
15	PIPE(C) - HIGH SIDE		4Y7163M01	1	1	1	1	
16	DRIER		P03584-01	1	1	1	1	
17	TIE		P05042-01	2	2	2	2	
18	PROSESS PIPE		4Y7164M01	1	1	1	1	
19	EVAPORATOR	(IM-45CNE)	3H5611G02	1	-	-	-	
			2E0053G01	-	1	1	1	
		(IM-45CNE-25)	3H3941G01	1	1	1	-	
			2E0056G01	-	-	-	1	
20	HOLDER - THERMISTOR		315479-01	1	1	1	1	
21	TRUSS HEAD TAPPING SCREW (S-TITE)		FTS0408M0	1	1	1	1	
22	HEAT EXCHANGER		4X5640G01	1	1	1	1	
23	PIPE(B) - HOT		3Y5859G01	1	1	1	1	
24	Insulation Tube - FSA		H81323450	1	1	1	1	
25	Insulation Tube (Food Sanitation Law)		H81020650	1	1	1	1	
26	NYLON TIE	CV-100	7920-0002	1	1	1	1	
27	NYLON TIE	CV-100	7920-0002	4	4	4	4	

IM-45CNE
IM-45CNE-25 C. ICE MAKING MECHANISM ASSY (A-1) and later

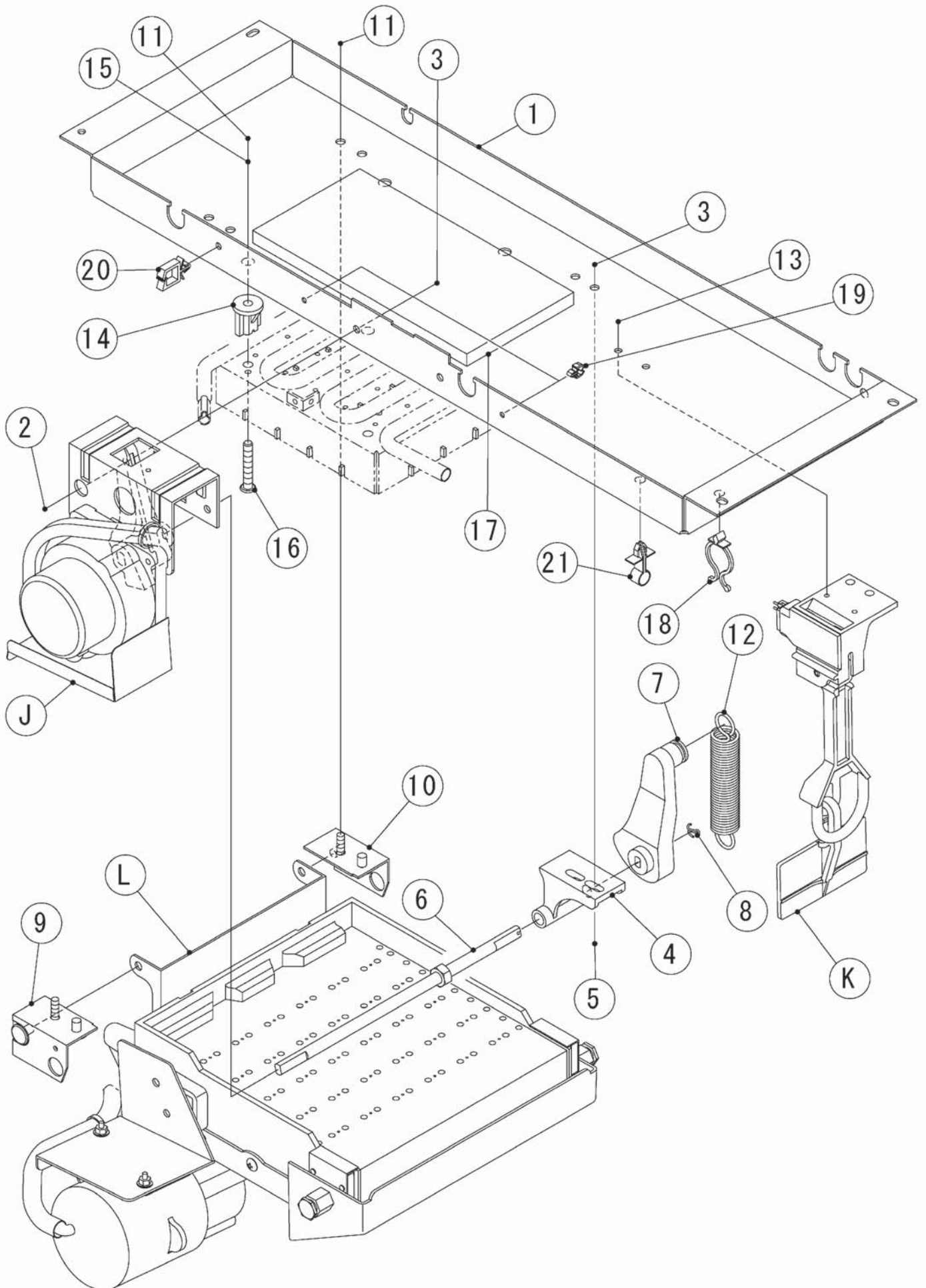

IM-45NE
 IM-45NE-25
 IM-45WNE
 IM-45WNE-25
 IM-45CNE
 IM-45CNE-25

D. WATER CIRCUIT ASSY

(A-1) and later

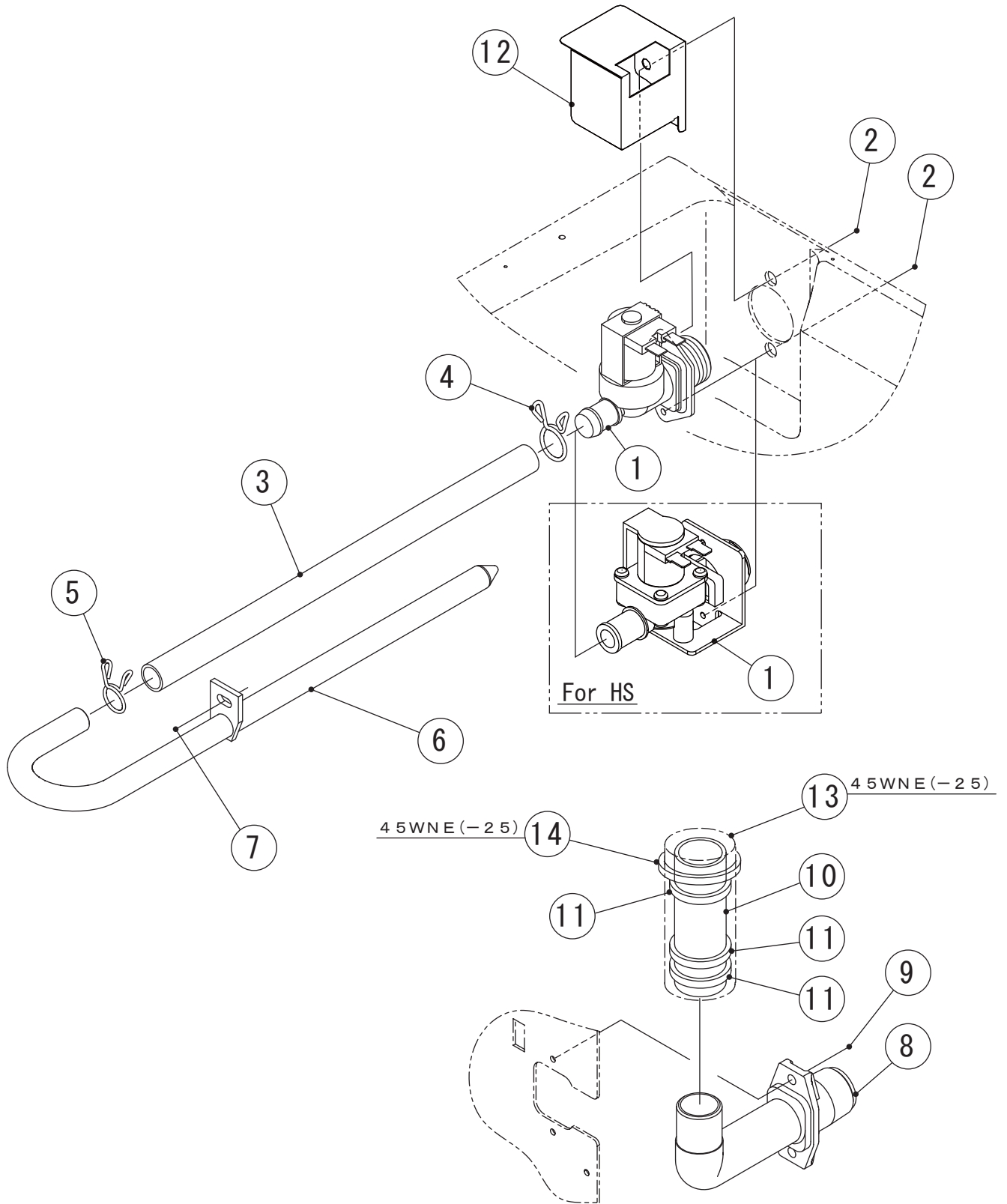

IM-45NE
IM-45NE-25
IM-45WNE
IM-45WNE-25
IM-45CNE
IM-45CNE-25

E. CONTROL BOX ASSY

(A-1) and later

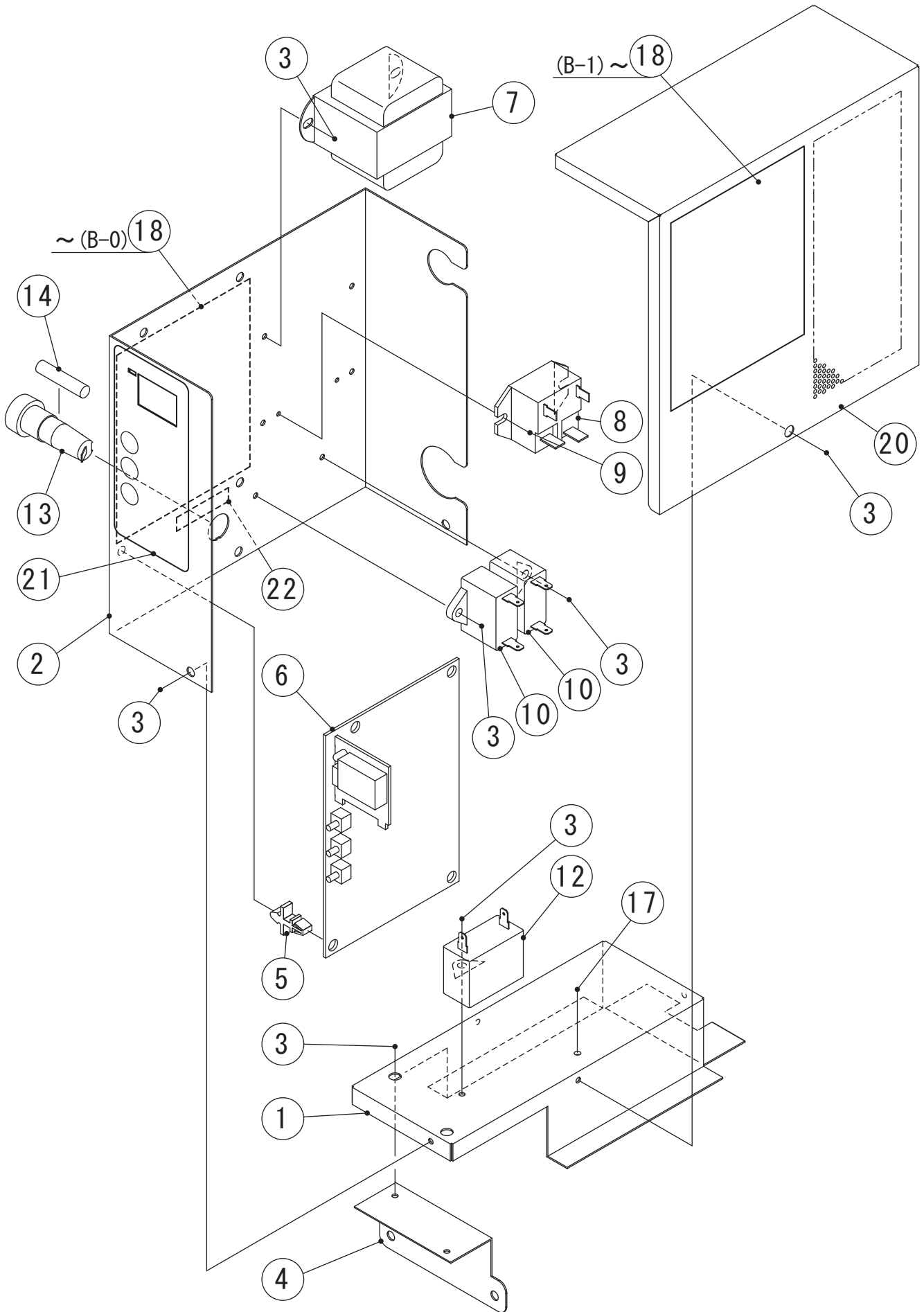

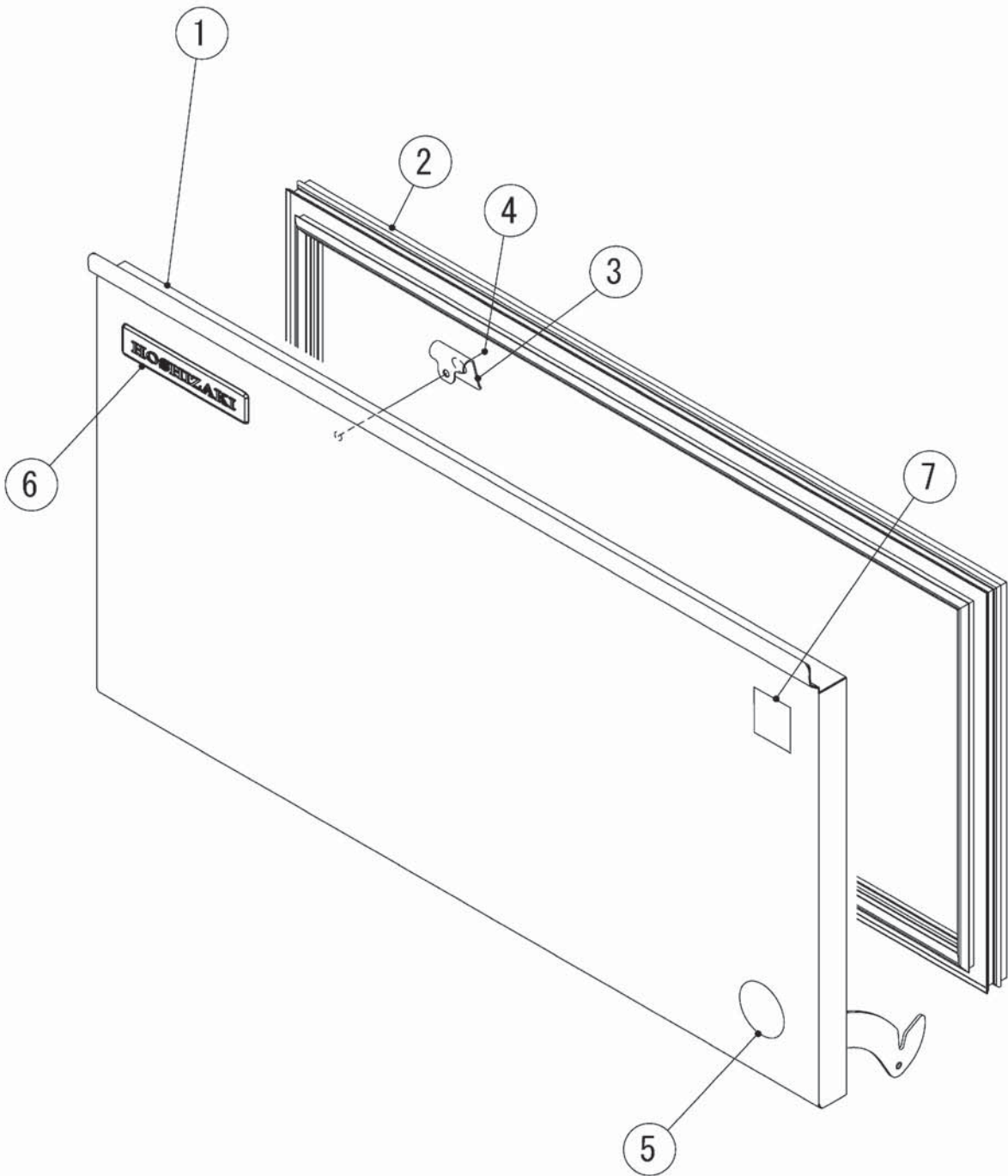

IM-45CNE
IM-45CNE-25 G. FRONT PANEL LOWER ASSY (A-1) and later

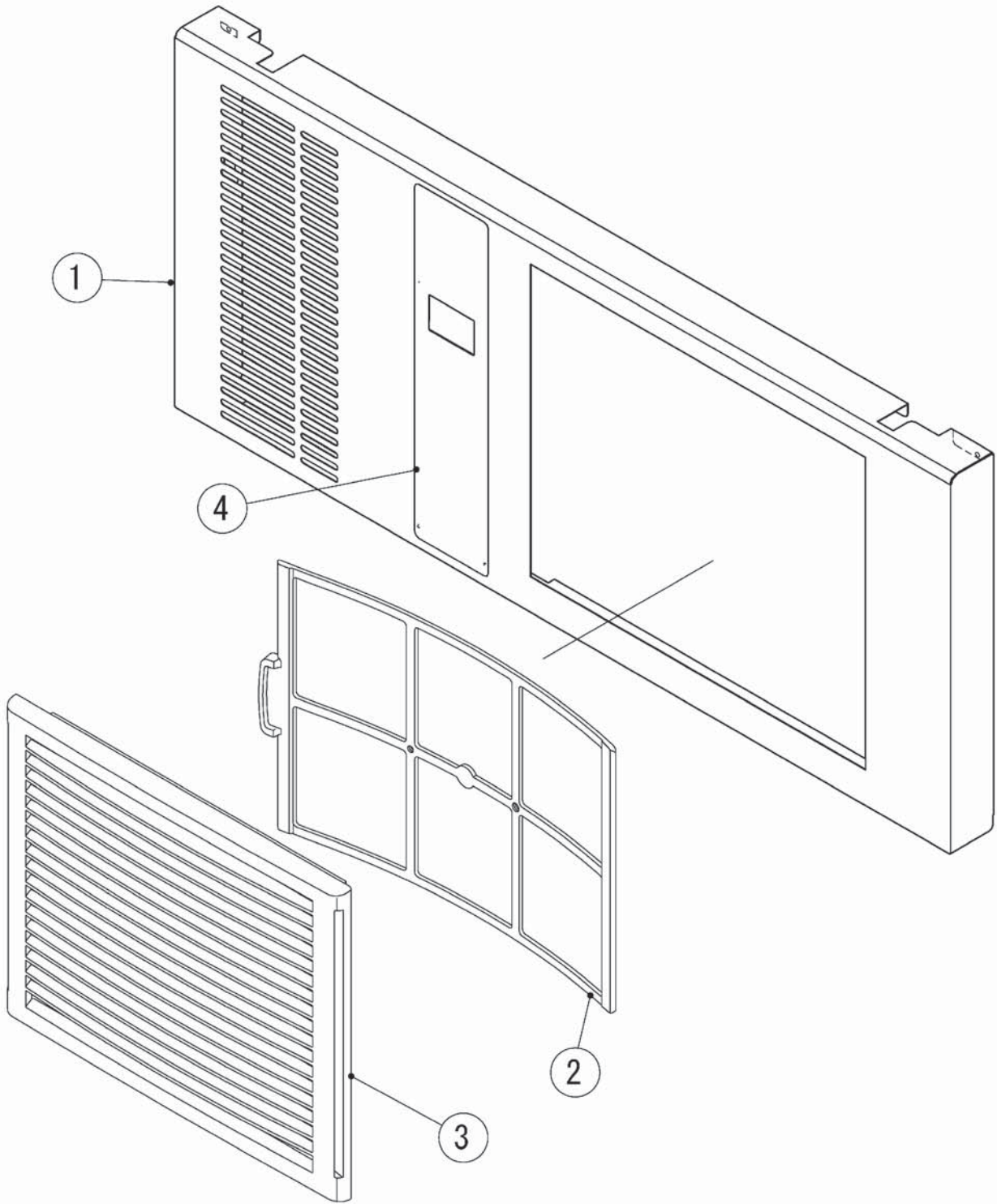

IM-45NE
IM-45NE-25
IM-45CNE
IM-45CNE-25

H. FAN MOTOR ASSY

(A-1) and later

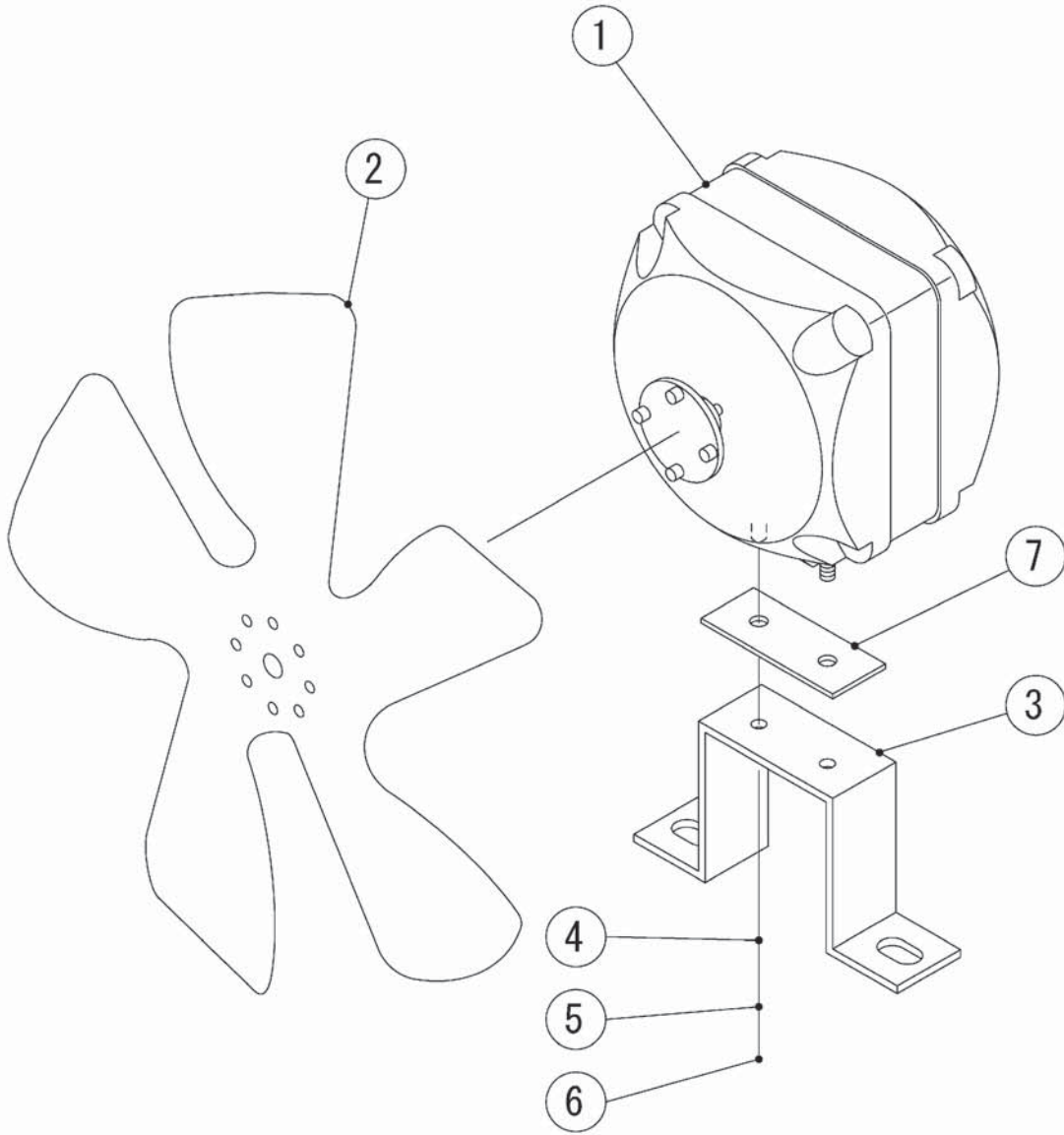

IM-45NE
IM-45NE-25
IM-45WNE
IM-45WNE-25
IM-45CNE
IM-45CNE-25

J. ACTUATOR MOTOR ASSY

(A-1) and later

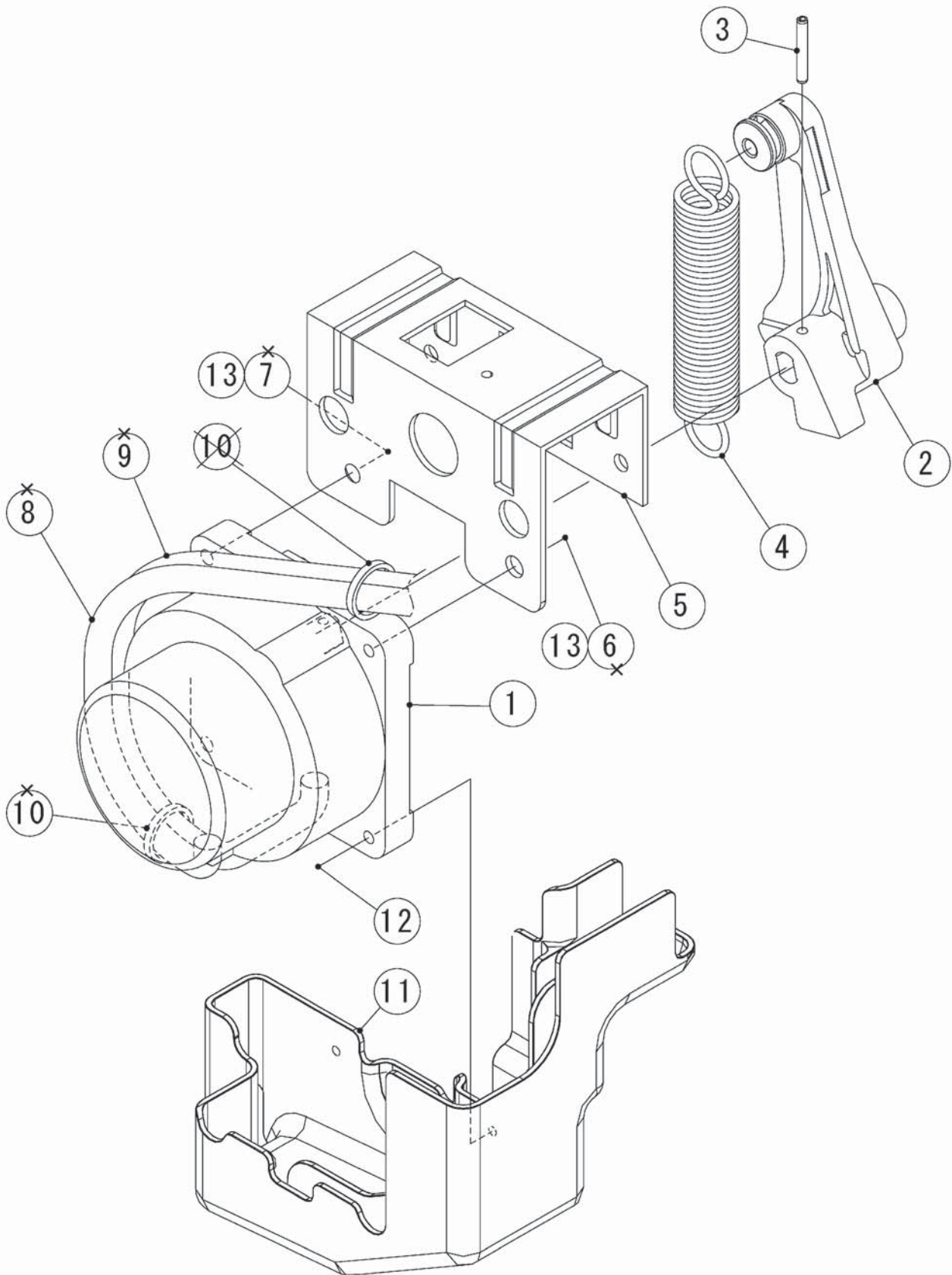

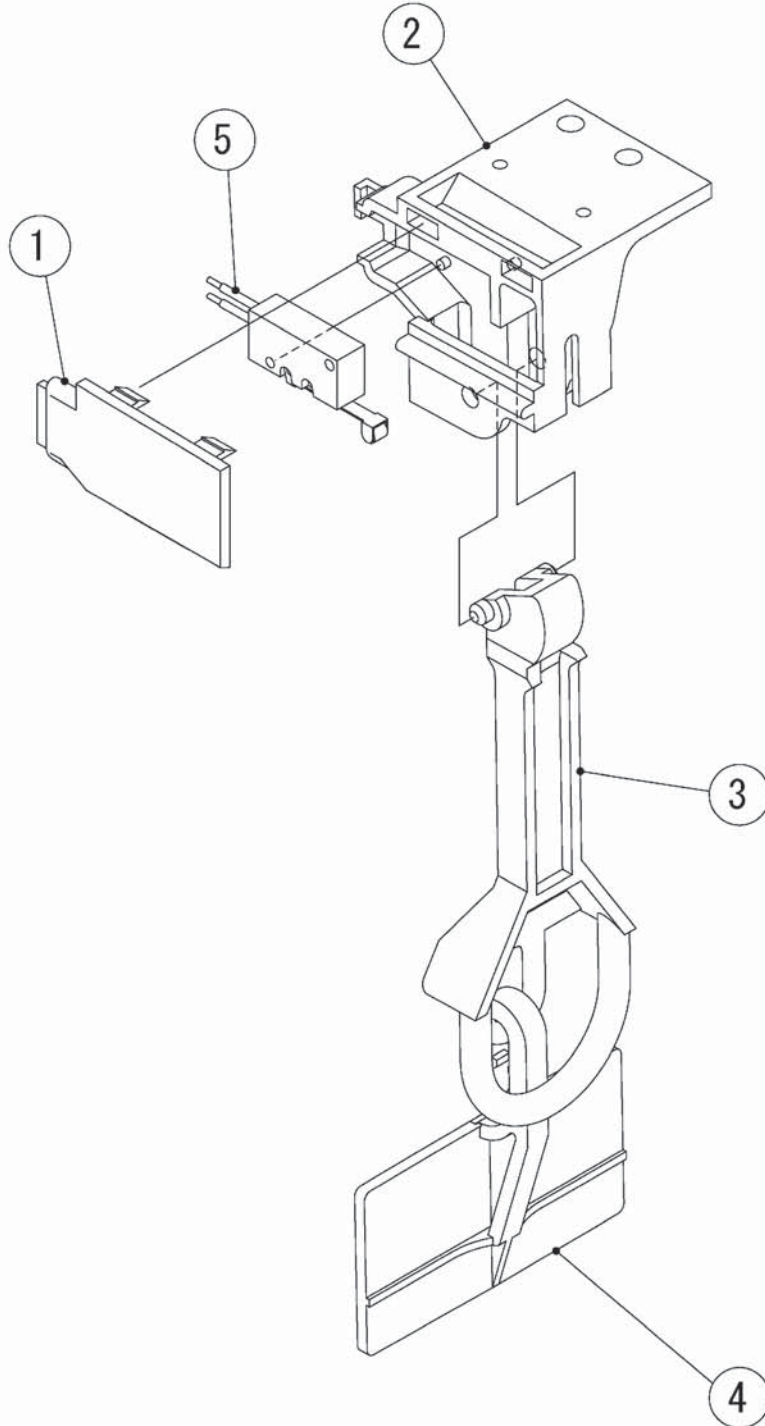

IM-45NE
IM-45NE-25
IM-45WNE
IM-45WNE-25
IM-45CNE
IM-45CNE-25

L. WATER PAN ASSY

(A-1) and later

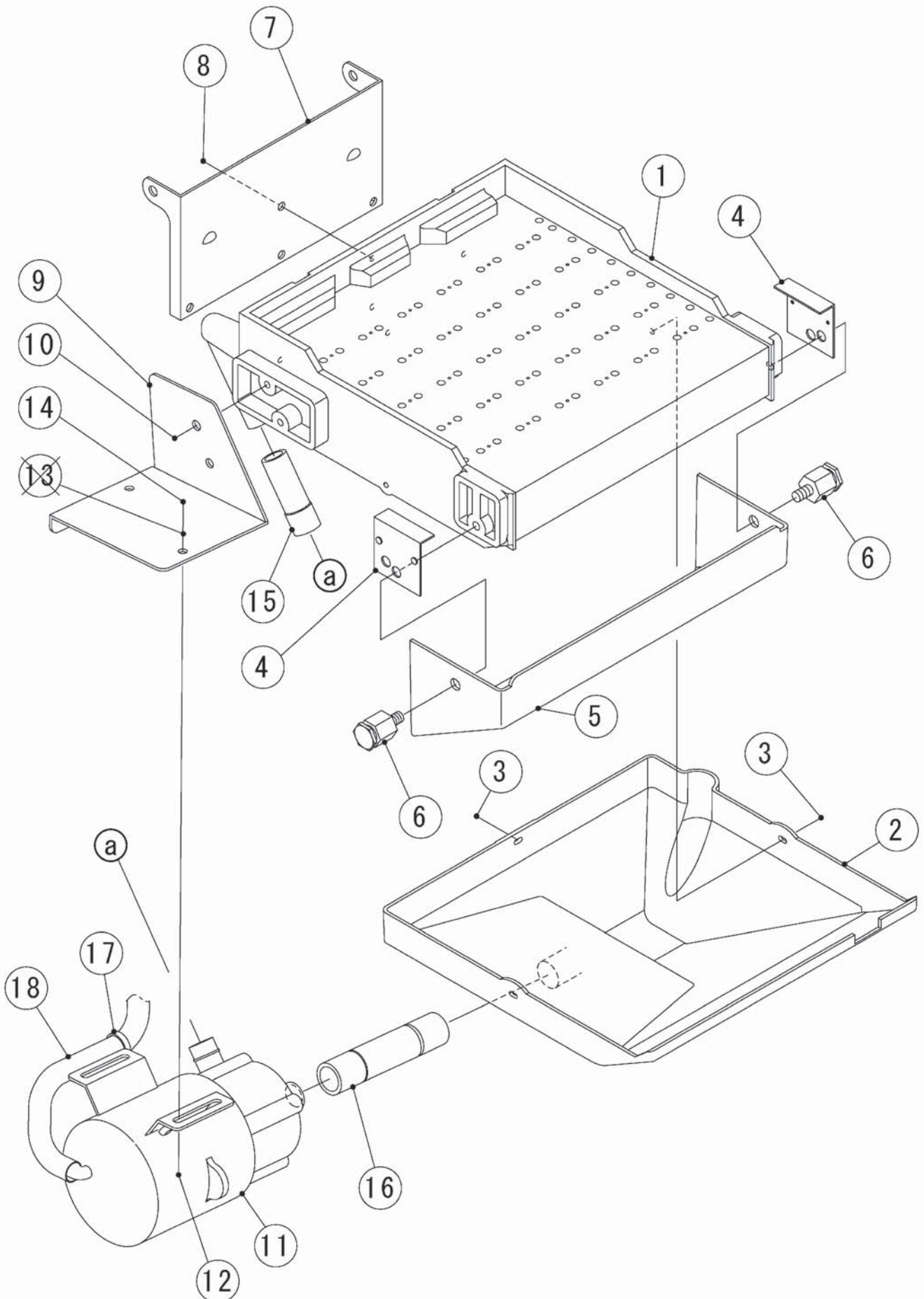

IM-45NE
IM-45NE-25
IM-45WNE
IM-45WNE-25
IM-45CNE
IM-45CNE-25

M. ACCESSORIES

(A-1) and later

