



MODULAR CUBER

INSTRUCTION MANUAL

IM-240ANE
IM-240AWNE



IM-240ANE

HOSHIZAKI EUROPE LIMITED

Telford 70 Stafford Park 7, Telford, Shropshire TF3 3BQ UK

L1E1CP113 (050818)

IMPORTANT SAFETY INFORMATION	1
I. INSTALLATION INSTRUCTIONS	3
1. CONSTRUCTION	3
2. ACCESSORIES	3
3. UNPACKING	3
4. LOCATION	4
5. INSTALLATION	5
6. ELECTRICAL CONNECTIONS	6
7. WATER SUPPLY AND DRAIN CONNECTIONS	6
II. OPERATING INSTRUCTIONS	8
1. START UP	8
2. PREPARING THE ICEMAKER FOR LONG STORAGE	8
III. MAINTENANCE	9
1. CLEANING	9
2. BEFORE CALLING FOR SERVICE	10
3. DISPOSAL	10
4. WARRANTY	11
SPECIFICATIONS	11

IMPORTANT SAFETY INFORMATION

Throughout this manual, notices appear to bring your attention to situations which could result in death, serious injury, or damage to the unit.

▲WARNING	Indicates a hazardous situation which, if not avoided, could result in death or serious injury.
▲CAUTION	Indicates a hazardous situation which, if not avoided, could result in minor or moderate injury.
NOTICE	Indicates a hazardous situation which, if not avoided, could result in damage to the unit.
▲HYGIENE	Indicates important precautions for hygiene and food safety.
IMPORTANT	Indicates important information about the use and care of the unit.

IMPORTANT	
This booklet is an integral and essential part of the product and should be kept and preserved by the user.	
Please read carefully the guidelines and warnings contained herein as they are intended to provide the installer/user with essential information for the proper installation and the continued safe use and maintenance of the product.	
Please preserve this booklet for any further consultation that may be necessary.	

▲WARNING	
This is a commercial icemaker, and should be destined only to be used for the purpose for which it has been expressly designed. Any other use should be considered improper and therefore dangerous. The manufacturer will not be held liable or responsible for any damage caused by improper, incorrect and unreasonable use.	
The installation, and relocation if necessary, must be carried out by qualified personnel, in accordance with current regulations, according to the manufacturer's instructions.	
Keep ventilation openings, in the appliance enclosure or in the built-in structure, clear of obstruction.	

ENGLISH

The use of any electrical appliance involves the observance of some fundamental rules. In particular:

- * Instances of high humidity and moisture increase the risk of electrical short circuits and potential electrical shocks. If in doubt, disconnect the icemaker.
- * Do not damage the power cord or pull it in order to disconnect the icemaker from the electrical supply network.
- * If the supply cord is damaged, it must be replaced by a replacement cord available from Hoshizaki Parts/Service Centres.
- * Do not touch the electrical parts or operate the switches with damp hands.
- * This appliance is not intended for use by persons (including children) with reduced physical, sensory or mental capabilities, or lack of experience and knowledge, it can however be used by children aged from 8 years and above and persons with reduced physical, sensory or mental capabilities, or lack of experience and knowledge providing they have been given supervision or instruction concerning use of the appliance by a person responsible for their safety.
- * Children shall not play with the appliance.
- * Cleaning and user maintenance shall not be made by children without supervision.
- * Do not attempt to modify the icemaker. Only qualified personnel may disassemble or repair the appliance.

I. INSTALLATION INSTRUCTIONS

1. CONSTRUCTION

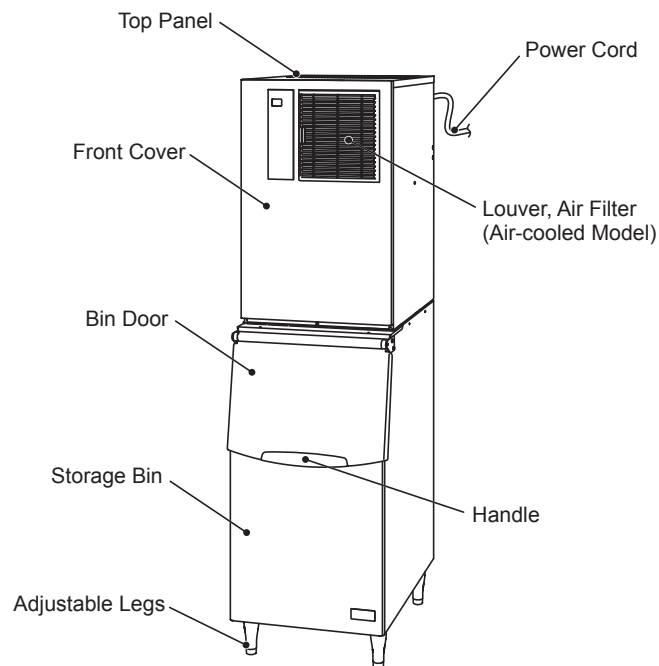

2. ACCESSORIES

	IM-240ANE	IM-240AWNE
CD	1	1
Inlet Hose	1	2
Outlet Hose	1	2
1/2-3/4 Nipple	-	2
Mounting Bracket	2	2
Hex Head Bolt M5 w/Washers	2	2
Ice Chute	1	1
Hex Head Bolt M4 w/Washers	2	2
Connector Cover	1	1
Power Cord	1	1

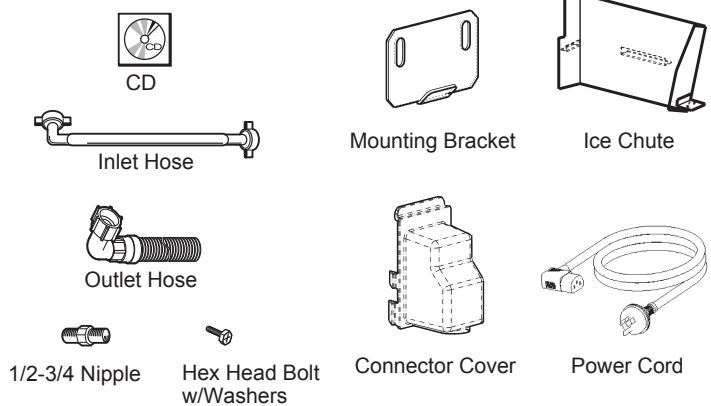

3. UNPACKING

⚠ WARNING

Children should not be allowed in reach of the packaging elements (plastic bags and expanded polystyrene) as they are potential sources of danger.

⚠ CAUTION

Do not lift or manoeuvre the carton by using the shipping bands.

When moving the unit by hand, remove the panels and hold the unit frame.

Always wear protective gloves when carrying the unit.

When handling the carton or the unpacked unit, work in pairs to prevent injury.

NOTICE

Remove shipping carton, tape(s) and packing. If packing material is left in the icemaker, it will not work properly.

ENGLISH

Note: This icemaker needs a storage bin. Hoshizaki recommends the following ice storage bins:

- B301SA-----IM-240ANE
- B501SA (Top Kit 8D) -----IM-240ANE
- B801SA (Top Kit 4DM)-----IM-240ANE x 2

- 1) After removing the packaging, make sure that the icemaker and the storage bin are in good condition. If in doubt, please do not use the icemaker but apply to professionally qualified personnel. See the instruction sheet attached to the storage bin for its unpacking and installation guidelines.
- 2) Remove the icemaker panels to gain access to the accessory kit and to assist easier installation.
- 3) Remove the package of accessories. Check the contents according to "2. ACCESSORIES".
- 4) Remove the shipping tape holding the bin control switch.
- 5) Remove the protective plastic film from the exterior. If the icemaker is exposed to the sun or to heat, remove the film after the icemaker cools.

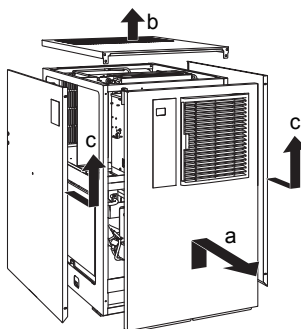

- a) Front Cover: Remove the screw(s). Lift up and pull toward you.
- b) Top Panel: Remove the screw(s). Simply lift off.
- c) Side Panel: Remove the screw(s). Slide forward slightly, and then lift off.
- d) Rear Panel: Does not require removal.

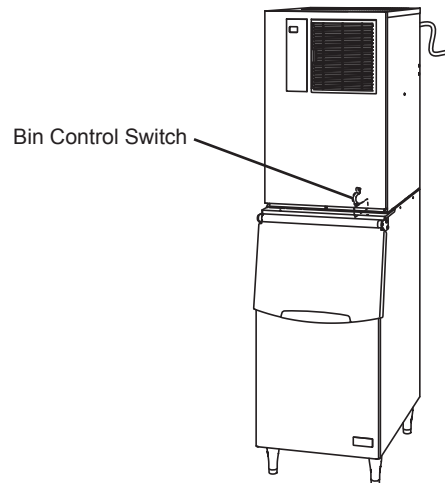

4. LOCATION

⚠ WARNING

This icemaker is not intended for outdoor use.

The icemaker should not be located next to ovens, grills or other high heat producing equipment.

This appliance is not suitable for installation in an area where a water jet could be used.

⚠ CAUTION

The location should provide a firm and level foundation for the icemaker.

NOTICE

Do not place anything on top of the icemaker or in front of the louver.

IMPORTANT

Normal operating ambient temperature should be within 1°C to 40°C. Water connection is cold water only. Operation of the icemaker, for extended periods, outside of these normal temperature ranges may affect production capacity.

Allow the clearance specified below for proper air circulation and ease of maintenance and/or service should they be required.

Side View
(Air-cooled model)

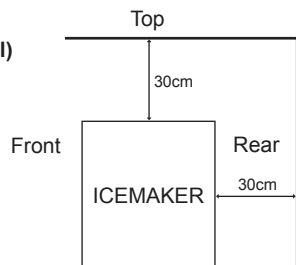

Side View
(Water-cooled model)

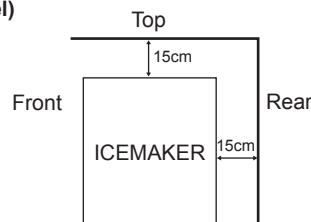

In some high humidity environments, condensation may form inside the machine and drip onto the floor. Do not install where the floor can be affected by water.

5. INSTALLATION

⚠ CAUTION

Incorrect installation can cause harm to people, animals or other items, for which the manufacturer cannot be held responsible.

- 1) Lay the storage bin on its rear side carefully to prevent damage. Secure the four adjustable legs (bin accessory) into the four tapped holes on the underside of the bin.
- 2) Position the storage bin in the selected permanent position, and level it in both the left-to-right and front-to-rear directions.

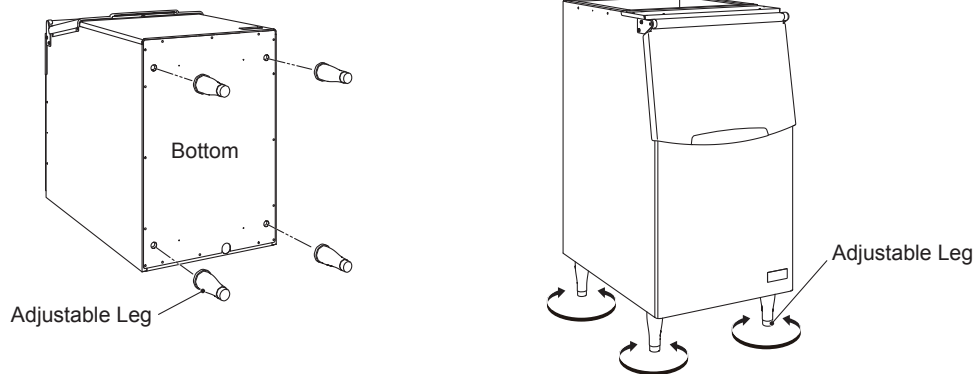

- 3) Remove the icemaker panels. The rear panel is not required to be removed for installation. See "3. UNPACKING".
- 4) Place the icemaker on the top of the storage bin by holding the bottom.
- 5) Secure the icemaker to the storage bin at the rear, by using the mounting brackets and bolts provided.
- 6) Seal the seam between the icemaker and the storage bin with food grade sealant.
- 7) Remove the drain pipe collar and drain pan. Secure the bin control switch to the mounting frame using the two bolts provided. Fix the bin control switch wiring with the two nylon ties. Place the ice chute on the unit frame, and refit the drain pan in its correct position.
- 8) Replace the icemaker panels in their correct position.

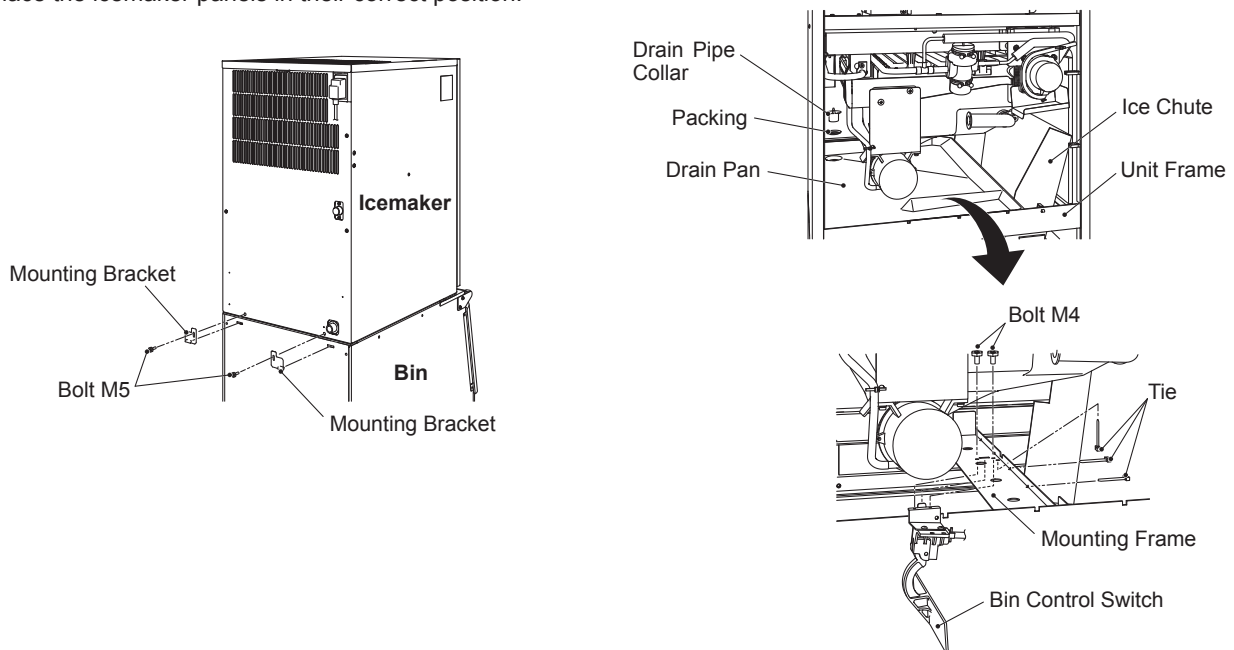

ENGLISH

6. ELECTRICAL CONNECTIONS

⚠ WARNING

THIS APPLIANCE MUST BE EARTHED

To prevent possible severe electrical shock to individuals or extensive damage to the unit, the icemaker must be connected via the flexible supply cord supplied with the icemaker to an appropriate outlet socket installed in accordance with local codes and regulations i.e. AS / NZS 3000.

Disconnect the main power supply before any maintenance, repairs or cleaning is undertaken.

- * It is recommended that these appliances are connected to a separate 240VAC supply, protected by an appropriate circuit breaker and Residual Current Device. Check the nameplate on the icemaker for the supply requirements.
- * Icemakers installed side by side should each have a separate receptacle, but they must all be connected in parallel to the same single phase supply or circuit with sufficient ampacity.
- * The main control box fuse is rated at 5A and should only be replaced by a qualified service engineer.
- * Usually an electrical permit and services of a licensed electrician are required.
- * In accordance with the requirement of the IEC standard, the maximum permissible system impedance (Z_{max}) at the interface point of the power supply to be connected with this icemaker must be $0.23+j0.23$ ohm. Determine in consultation with the supply authority, if necessary, that the icemaker is connected only to a supply of $0.23+j0.23$ ohm or less.
- * The wires in the mains lead are coloured in accordance with the following code:
 - Green & Yellow = Earth
 - Blue = Neutral
 - Brown = Live

7. WATER SUPPLY AND DRAIN CONNECTIONS

⚠ WARNING

Connect to potable cold water supply only.

- * The service of a licensed plumber may be required to ensure the installation is in accordance with the local codes and regulations.

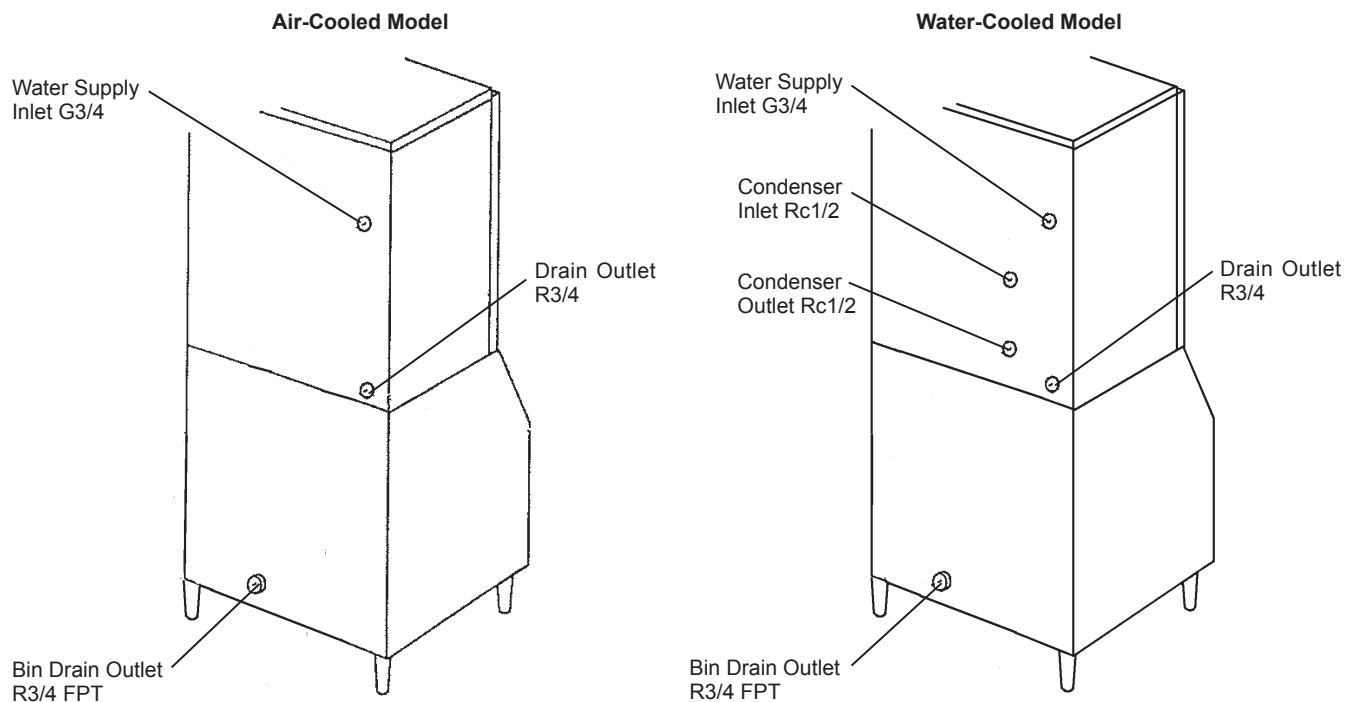

[Connection to the water supply]

* The connections to the mains water supply must be made in accordance with the Plumbing Code of Australia and in accordance with AS / NZS 3500.1 and AS / NZS 3500.2. This appliance incorporates backflow protection complying with AS / NZS 3500.1. No further backflow protection is required for connection to the water supply.

* Icemaking water must be potable water. Where scaling can be caused by water quality:

- Installation of an external filter or softener is recommended. Contact your local water treatment professional or Hoshizaki service agent.
- Change to the "full drain flush" mode is recommended. Contact your local Hoshizaki service agent.

* Water supply pressure should be minimum 0.07 MPa (0.7 bar) and maximum 0.78 MPa (8 bar). If the pressure exceeds 0.78 MPa (8 bar), use a proper pressure reducing valve. Do **NOT** throttle back the supply tap.

* Attach the angle end of the inlet hose to the G3/4" water inlet fitting on the rear of the icemaker.

* Be sure to use the new inlet hose-sets supplied with the appliance. Do not reuse any other inlet hose-set.

* Ensure rubber tap washers are correctly positioned. Hand tighten the inlet hose sufficiently to provide a leak free joint.

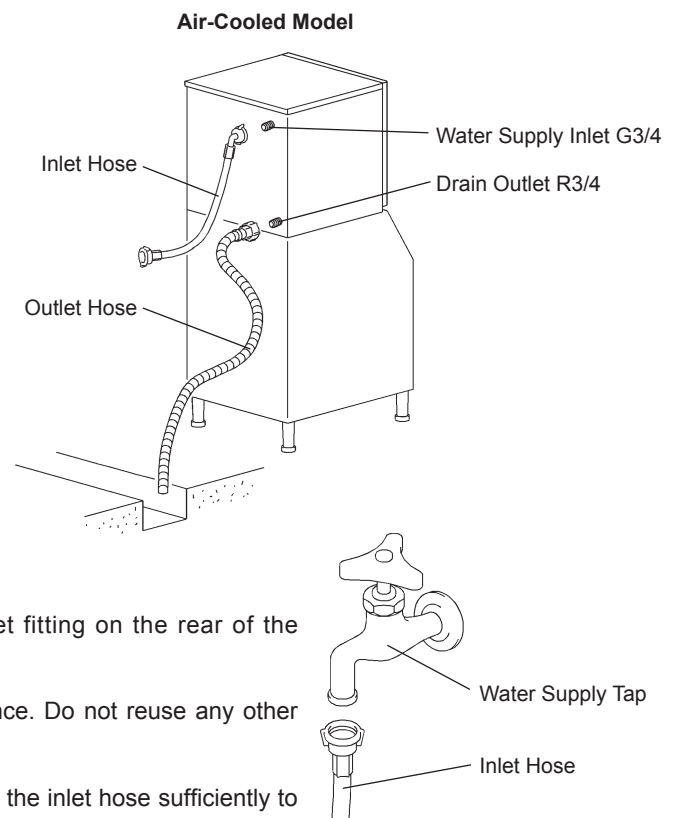

[Connection to the drain]

* Hand tighten grey flexible outlet hose (accessory) onto the R3/4 fitting on the rear of the icemaker as indicated, ensuring rubber washer is correctly positioned to obtain a leak free joint. The hose can be cut to length as necessary to suit position of main drain.

* Drain lines should not be installed directly to the sewer system. A vertical air gap of a minimum of 5 cm should be between the end of the drain hoses from the icemaker and the floor drain.

* To prevent a backflow into the storage bin, the outlet hose must be laid as shown.

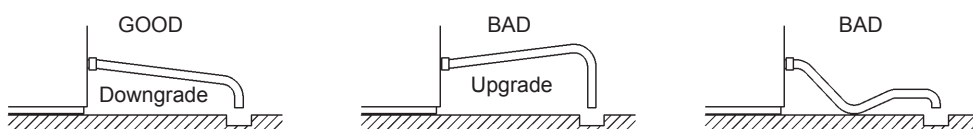
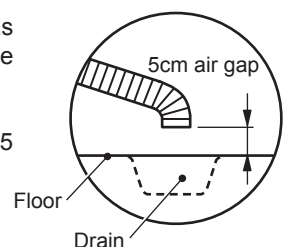

Water-Cooled Model:

[Connection to the water-cooled condenser]

* Hoshizaki recommends that the water-cooled condenser should be connected to a closed circuit recirculating type cooling system utilizing a tower, water chiller or similar. Water make up should be via a ball valve/break tank arrangement.

* The service of licensed plumber may be required to ensure the installation is in accordance with the local codes and regulations.

* When selecting a cooling tower, refer to the following peak values of heat flow in the condenser:

Model IM-240AW: 5235 W

* Pipes between the cooling tower and the icemaker should be at least 20 mm DIA to reduce pressure loss, even though the icemaker fittings are 13 mm DIA.

* Pressure loss in the water circuit inside the unit will be 5 to 6 m when the cooling water flows at the ratio of 4 to 5 lit/min.

* Do not use a cascade pump, or the water regulator will vary the flow and stop it during the defrost cycle.

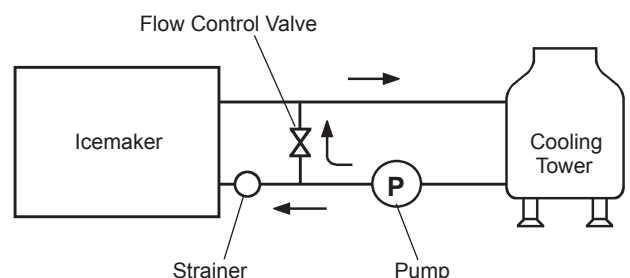

ENGLISH

II. OPERATING INSTRUCTIONS

⚠ CAUTION

Do not step into the storage bin, or put your hands into the back of the storage bin or the ice chute on top of the storage bin. Ice may drop off the icemaker, a hard block of ice may suddenly break down, or the icemaking mechanism may suddenly move, resulting in injury.

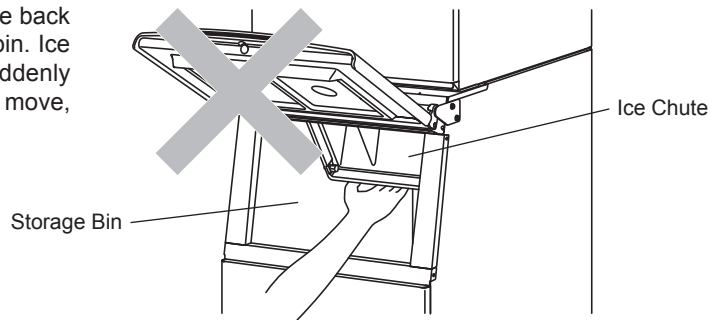

NOTICE

All parts are factory-adjusted. Improper adjustments may result in failure.

If the unit is turned off, wait for at least 3 minutes before restarting the icemaker to prevent damage to the compressor.

⚠ HYGIENE

This icemaker is designed to produce edible ice. To keep the icemaker hygienic:

- * Wash your hands before removing ice. Use the plastic scoop provided (accessory).
- * The storage bin is for ice use only. Do not store anything else in the bin nor use other electrical appliances in the bin.
- * Clean the storage bin before use (see "III. 1. CLEANING").
- * Keep the scoop clean. Clean it by using a neutral cleaner and rinse thoroughly.
- * Close the door after removing ice to prevent entrance of dirt, dust or insects into the storage bin.

1. START UP

The installer will normally commission the icemaker to start the automatic icemaking process. To ensure continuous operation, make sure that:

- * The water supply tap is on, and
- * The icemaker is connected to the power supply.

2. PREPARING THE ICEMAKER FOR LONG STORAGE

NOTICE

This icemaker will not work at subfreezing temperatures. To prevent damage to the water supply line, drain the icemaker when air temperature is below zero.

⚠ HYGIENE

When shutting down the icemaker for two or more days, drain the icemaker to prevent contamination in the water circuit.

- 1) Unplug the icemaker or disconnect the power supply.
- 2) Close the water supply tap, and remove the inlet hose.
- 3) Remove all ice from the storage bin, and clean the bin.
- 4) Ask for draining of the icemaker by professional qualified personnel.

III. MAINTENANCE

1. CLEANING

⚠ WARNING

Before carrying out any cleaning or maintenance operations, unplug the icemaker from the electrical supply network.

This appliance must not be cleaned by use of a water jet.

⚠ CAUTION

When using a neutral cleaner or sodium hypochlorite, thoroughly read and understand the instructions provided to prevent potential health problems.

NOTICE

Ask a trained service person to clean and sanitise the icemaker water system at least twice a year and to check and clean the condenser at least once a year.

To prevent possible damage, do not clean the plastic parts with water above 40°C or in a dishwasher.

IMPORTANT

For spare parts information, contact your local Hoshizaki service agent.

[a] Machine and Bin Exterior

Wipe the exterior at least once per week with a clean, soft cloth. Use a damp cloth containing a neutral cleaner to wipe off grease or dirt.

[b] Scoop and Storage Bin Handle Cleaning/Sanitisation (Daily)

- 1) Either mix 1 litre of water with 4 ml of 5.25% sodium hypochlorite solution in a suitable container, or the recommended Hoshizaki sanitiser as directed.
- 2) Soak the scoop in the solution for more than 3 minutes. Rinse thoroughly, and shake to remove surplus liquid.

Note: Using a cloth to dry may re-contaminate.

- 3) Use a neutral cleaner to wash the storage bin handle. Rinse thoroughly.
- 4) Soak a clean cloth with the sanitising solution, and wipe the handle. Use fresh water and a clean cloth to rinse/dry.

[c] Storage Bin Interior Cleaning/Sanitisation (Weekly)

- 1) Open the storage bin door, and remove all ice.

Note: Hoshizaki recommends various types of storage bin for the icemaker which vary in size and design. The following instructions are therefore for general guidance only.

- 2) Remove the thumbscrews securing the baffle.
- 3) Remove the baffle from the bin.
- 4) Wash the bin liner and baffle with a neutral non-abrasive cleaner. Rinse thoroughly.
- 5) Either mix 5 litres of water with 18 ml of 5.25% sodium hypochlorite solution in a suitable container, or the recommended Hoshizaki sanitiser as directed.
- 6) Soak a clean sponge or cloth with the solution, and wipe the bin liner surfaces and baffle.
- 7) Refit the baffle and thumbscrews. Wipe the surface of the bin door and thumbscrews with the solution. Close the bin door.
- 8) The remaining solution can be used to sanitise utensils.

Note: Do not wipe dry or rinse after sanitising, but allow to air dry.

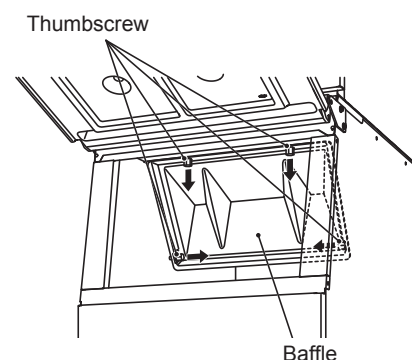

ENGLISH

[d] Air Filter (Air-Cooled Model Only)

Plastic mesh air filters remove dirt or dust from the air, and keep the condenser from getting clogged. If the filters get clogged, the icemaker's performance will be reduced. Remove and clean the air filter(s) at least twice per month:

- 1) Slide the air filter off the louver.
- 2) Clean the air filter by using a vacuum cleaner. When severely clogged, use warm water and a neutral cleaner to wash the air filter.
- 3) Rinse and dry the air filter thoroughly.

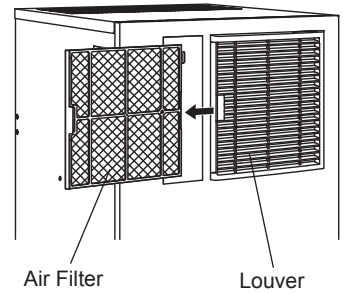

NOTICE
After cleaning, be sure to place the air filter back in position.

2. BEFORE CALLING FOR SERVICE

⚠ WARNING
Do not damage the refrigerant circuit.

[a] Error Code Indication

If the error code "E" is indicated on the display, before calling for service, check the following.

Code	Remedy
E1	Freeze error. Unplug unit and plug it back in after 3 minutes. Clean air filter (air-cooled model). Lower ambient temperature or ensure adequate clearance around unit (see "I. 2. LOCATION"). If error persists, call for service.
E2	Defrost error. Unplug unit and plug it back in after 3 minutes. If error persists, call for service.
EE	Other error. Unplug unit and plug it back in after 3 minutes. Clean air filter (air-cooled model). Check for water failure or closed water supply tap. Lower ambient temperature or ensure adequate clearance around unit (see "I. 2. LOCATION"). If error persists, call for service.

[b] No Error Code Indication

If the icemaker does not work properly or does not work at all and no error code is indicated on the display, before calling for service, check that:

- * The power is supplied to the unit.
 - * The water is turned on.
 - * The air filter is clean (air-cooled model).
 - * The cooling water circuit has a proper flow (water-cooled model).
- For further assistance or advice, contact your local Hoshizaki service agent.

3. DISPOSAL

Comply with local regulations regarding disposal of this appliance and its refrigerant gas. Before you scrap the appliance, take off the door to prevent children trapped.

Correct disposal of this product:

This marking indicates that this product should not be disposed with other household wastes throughout the EU. To prevent possible harm to the environment or human health from uncontrolled waste disposal, recycle it responsibly to promote the sustainable reuse of material resources. To return your used device, use the return and collection systems or contact the retailer where the product was purchased. They can take this product for environmental safe recycling.



4. WARRANTY

Hoshizaki warrants to the original owner/user that all Hoshizaki branded products shall be free of defects in material and/or workmanship for the duration of the “warranty period”. The warranty shall be effective for one year from the date of installation. Hoshizaki’s liability under the terms of the warranty are limited and shall exclude routine servicing, cleaning, essential maintenance and/or repairs occasioned by misuse and installations not in accordance with Hoshizaki guidelines.

Warranty repairs should be completed by an approved Hoshizaki dealer or service agency using genuine Hoshizaki components.

To obtain full details of your warranty and approved service agency, please contact your dealer/supplier, or the nearest Hoshizaki Service office:

Hoshizaki Lancer
 TEL: +61 8 8268 1388
 FAX: +61 8 8268 1978
 info@hoshizaki.com.au
 http://www.hoshizaki.com.au

To register your product for warranty with Hoshizaki, visit <http://www.hoshizaki.com.au/warranty-registration> or scan the QR code.



SPECIFICATIONS

Model	IM-240ANE	IM-240AWNE
Type	Air-cooled, cube ice	Water-cooled, cube ice
Power Supply	1 phase 220 - 240V 50Hz	1 phase 220 - 240V 50Hz
Electric Consumption	1320W	1300W
Ice Production per 24h	220kg (5mm) / 240kg (15mm) (ambient temp 10°C, water temp 10°C)	230kg (5mm) / 240kg (15mm) (ambient temp 10°C, water temp 10°C)
Dimensions	560mm(W) x 700mm(D) x 880mm(H)	560mm(W) x 700mm(D) x 880mm(H)
Refrigerant	R404A, 0.48kg (GWP: 1430, CO2: 1.882t)	R404A, 0.45kg (GWP: 1430, CO2: 1.764t)
Insulation Foam Blowing Agent	HFC-free	HFC-free
Weight	Net: 80kg (Gross: 91kg)	Net: 83kg (Gross: 94kg)
Ambient Temp	1 - 40°C	1 - 40°C
Water Supply Temp	5 - 35°C	5 - 35°C
Water Supply Pressure	0.07 - 0.78 MPa (0.7 - 8 bar)	0.07 - 0.78 MPa (0.7 - 8 bar)
Voltage Range	Rated voltage ± 6%	Rated voltage ± 6%

Note: The above specifications are for the representative models.

This product includes a hermetically sealed refrigeration system that contains fluorinated greenhouse gases.