



# HOSHIZAKI

## HFE-70B-ALD-GN

Upright Freezer

### PRODUCT FEATURES

- Stainless steel interior and exterior.
- Lockable Full Length Door
- Programmable Digital controller and display.
- 4 x 2/1 Gastronorm adjustable shelves with rails
- 2 years parts and labour warranty.
- Comes standard with 4 x 115mm lockable castors (not legs).
- Optional Adjustable legs 150 - 180mm (Sold separately).

### TECHNICAL DRAWING

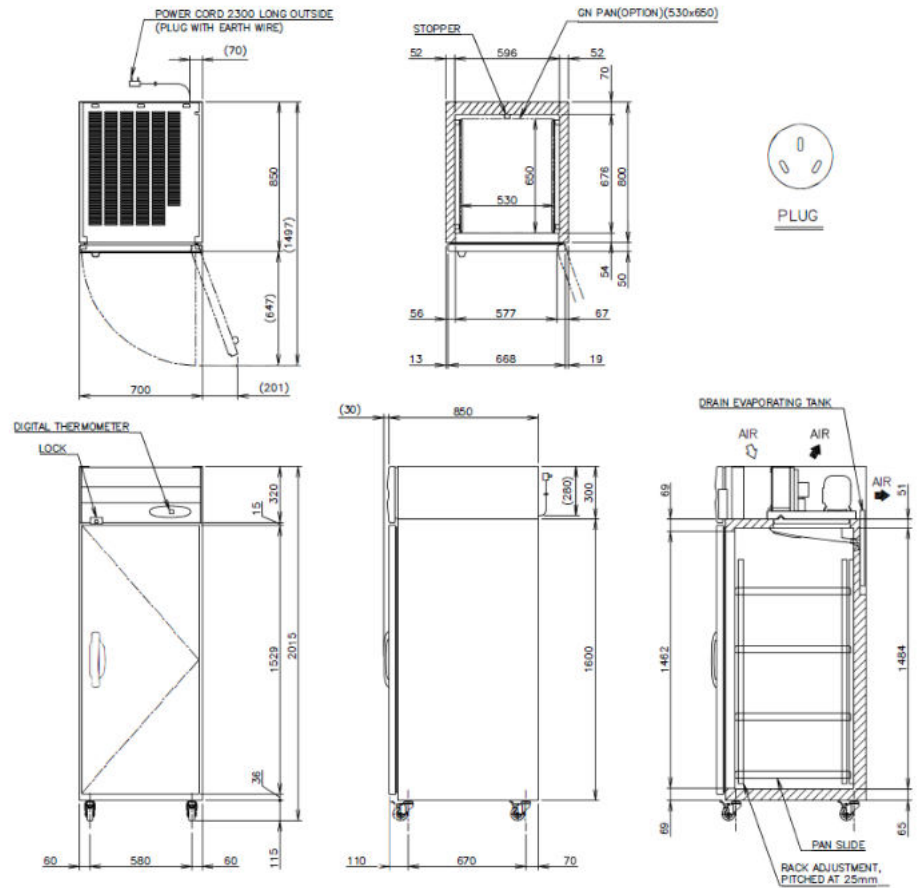

### PRODUCT SPECIFICATION

Exterior	Stainless Steel, Galvanized Steel (Rear /Bottom)
Interior	Stainless Steel
Max Storage Capacity	630L
Temperature Control	Microprocessor controlled Adjustable from -25 to -7°C
Evaporator	Fin & Tube type
Outside Dimensions	700mm (W) x 850mm (D) x 2015mm (H)
Inside Dimensions:	596mm (W) x 676mm (D) x 1484mm (H)
Refrigeration System	Forced Air Circulation
Weight Net/Gross (kg)	130 / 152
AC Supply Voltage	1 PHASE 220 - 240V 50Hz /10amp Plug
Amperage	Rated: 3.57A Starting: 14.8A
Refrigerant	R404A/230g
Operating Conditions	Ambient Temp.: 5-43°C Voltage Range: Rated Voltage ±6%



Descriptions and specifications are subject to change at any time, without notice. Illustrations for demonstration purposes.

Copyright © 2020 Hoshizaki Lancer Pty Ltd. All right reserved. E&OE Date: Sept2020