



HOSHIZAKI

FTC-90DEA-GN-3D

Drawer Undercounter Freezer

PRODUCT FEATURES

- Stainless steel interior and exterior.
- Programmable Digital controller and display.
- 3 x Auto closing drawers
- Fits GN pans 100mm Deep
- Compact slide out refrigeration unit for quick maintenance.
- 2 years parts and labour warranty.
- Comes standard with 115mm lockable castors (not legs).
- Optional Adjustable legs 150 - 180mm (Sold separately).

TECHNICAL DRAWING

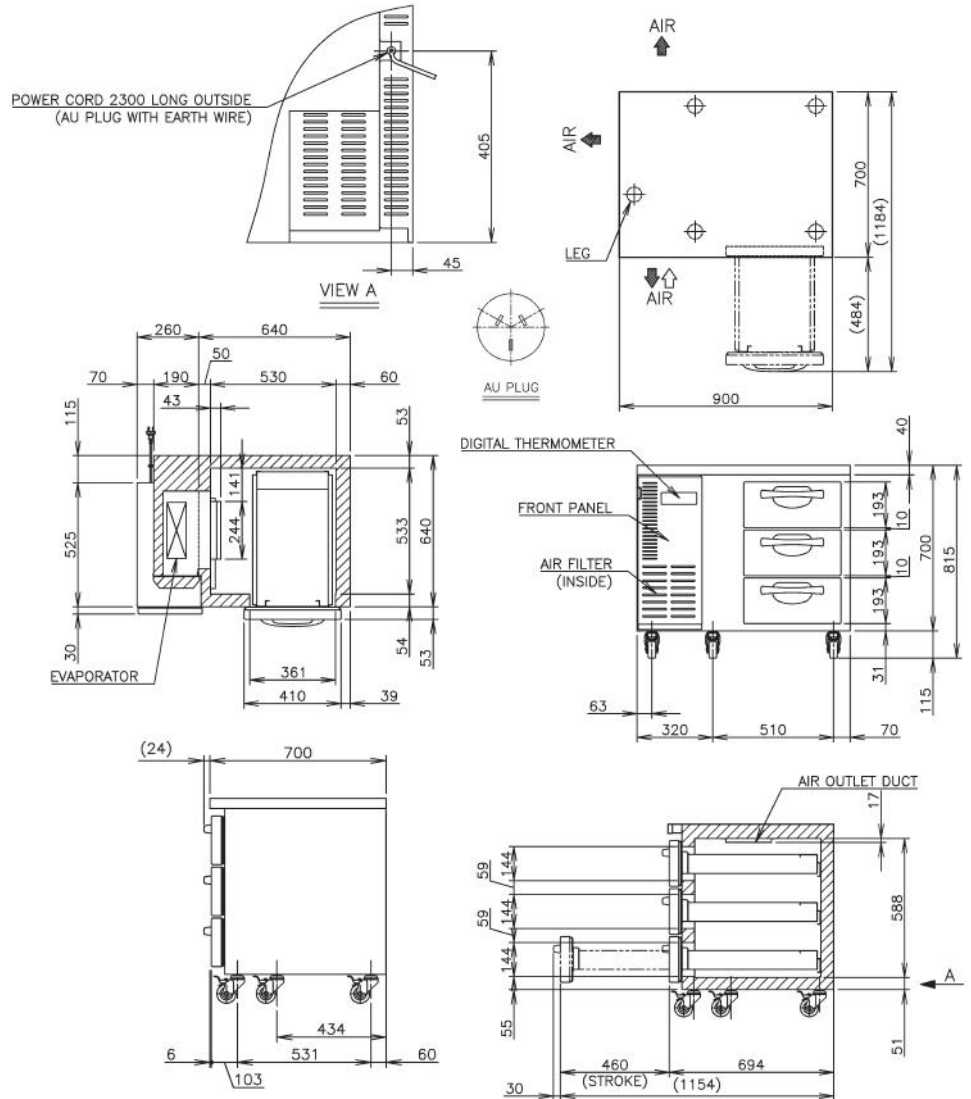

PRODUCT SPECIFICATION



Exterior	Stainless Steel, Galvanized Steel (Rear /Bottom)
Interior	Stainless Steel, ABS Plastic
Max Storage Capacity	160L
Temperature Control	Microprocessor controlled Adjustable from -25 to -7°C
Drain Evaporator Pan	Fin & Tube type
Outside Dimensions	900mm (W) x 700mm (D) x 815mm (H)
Inside Dimensions	530mm (W) x 533mm (D) x 588mm (H)
Refrigeration System	Forced Air Circulation
Weight Net/Gross (kg)	86
AC Supply Voltage	1 PHASE 220-240V 50Hz /10amp Plug
Amperage	Rated: 3.0A
Refrigerant	R404A / 200g
Operating Conditions	Ambient Temp.: 5-43°C Voltage Range: Rated Voltage ±6%



Descriptions and specifications are subject to change at any time, without notice. Illustrations for demonstration purposes.

Copyright © 2020 Hoshizaki Lancer Pty Ltd. All right reserved. E&OE Date: Sept 2020