



HOSHIZAKI

DCM-120KE-P

105KG Ice & Water Dispenser

Model Number
91000115

PRODUCT FEATURES

- Premium Cubelet ice
- Smooth ice dispense
- No ice bridging
- Robust and reliable
- Sanitary self-service application
- Easy operation - Push button; dispense ice directly into container greatly reducing risk of contamination
- Dispenses ice only, water only or ice and water
- Adjustable portion-controlled dispensing
- Due to Auger system water consumption is equal to ice production.
- 2-year parts & labour on entire unit, 5 year (parts only) on compressor & air-cooled condenser coil



TECHNICAL DRAWING

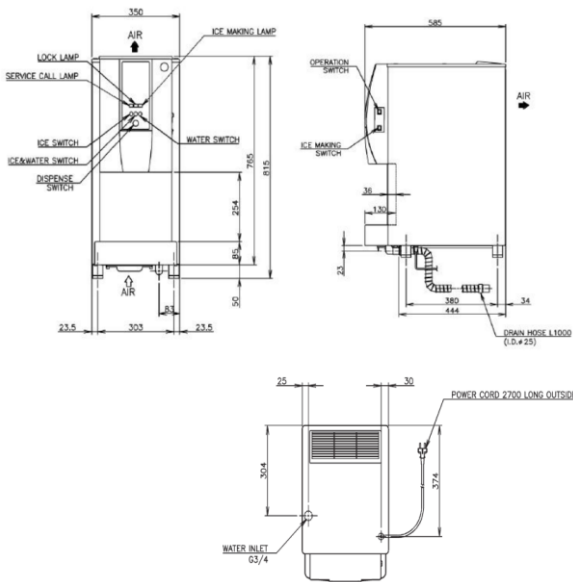

PRODUCT SPECIFICATION

Production Capacity / 24hrs	Approx. 125kg @ 10°C Air temp; 10°C Water Approx. 105kg @ 21°C Air temp; 15°C water Approx. 85kg @ 32°C Air temp; 21°C water
Max Storage Capacity	Approx. 4kg
Dimensions	350mm (W) x 585mm (D) x 815mm (H)
Cooling	Air
Weight Net/Gross (kg)	71/82
Refrigerant Charge	R134a / 200g
AC Supply Voltage	1 PHASE 220-240V 50Hz/ 10 AMP Plug
Amperage	Rated: 2.8 / 2.7 A Starting: 12.6 A
Operating Conditions:	
Ambient Temp	5-40°C
Water Supply Temp	5-35°C
Water Supply Pressure	0.07-0.8MPa (0.7-8bar)
Voltage Range	±6%

INSTALLATION REQUIREMENTS

- Ensure the condenser is cleaned periodically as per the manufacturer's manual.
- Do not plug the unit into multi-plug power boards with other appliances
- Room ventilation or air conditioning can improve the situation by reducing the humidity.
- Hoshizaki recommends the use of a compatible water filter to prevent non-warrantable scale & sediment complications.

*Refer to manual for full installation & maintenance requirements.



For free 6 month extended warranty, register online within 4 weeks of purchase date.
hoshizaki.com.au

