



HOSHIZAKI DB-200H-Worksite-H2O

Model Number
91000131

90KG DISPENSER

PRODUCT FEATURES

- Produce more quality ice.
- Clear, hard individual uniquely shaped Crescent cubes that last longer in drinks.
- Use less energy.
- Cycle 1/2 as many times as competition.
- Crescent cubes do not clump together in storage bins.
- Unique stainless steel evaporator design which is unaffected by caustic water, harsh cleaning agents and does not crack or peel like nickel plated evaporators.
- Long-life stainless-steel construction.
- Inbuilt, removable, easily cleaned, reusable air filters.
- Compatible Modular Head unit KMD-201AA, KMD-270AA or KM-660MAJ-E or KM-470AJ-S & Top Kit (Sold Separately)



*Ice Machine not included

TECHNICAL DRAWING

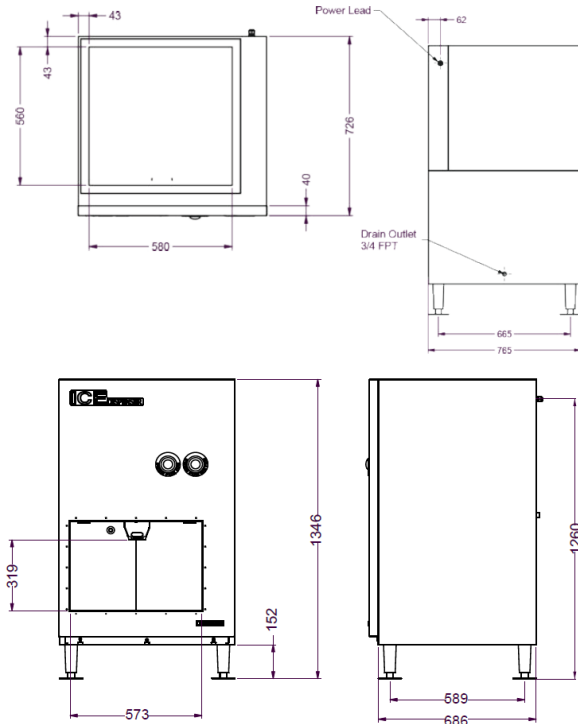

PRODUCT SPECIFICATION

Push Button	1 x Ice & 1 x Water Single Auger Agitator
Max Storage Capacity	Approx. 90kg
Dimensions	762mm (W) x 684mm (D) x 1346mm (H)
Weight Net	85kg
AC Supply Voltage	1 PHASE 240V/50Hz/10AMP Plug
Amperage	Rated:1.4A
Operating Conditions	Ambient Temp.: 7-38°C Voltage Range: 104 -132V
Compatible	KMD-201AA, KMD-270AA or KM-660MAJ-E or KM-470AJ-S & Top Kit (Sold Separately)

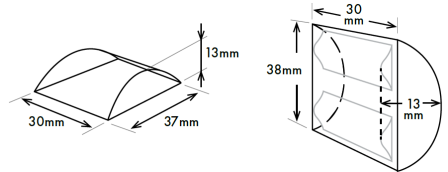

For free 6 month extended warranty, register online within 4 weeks of purchase date.
hoshizaki.com.au

