

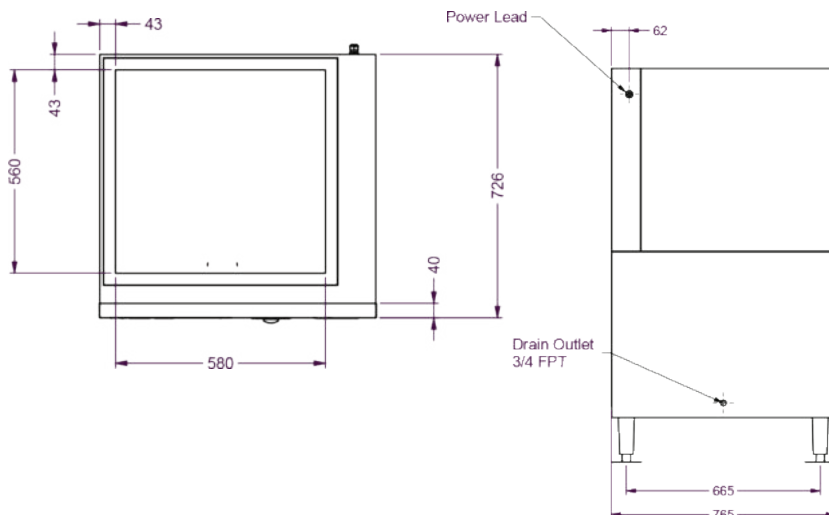

PRODUCT FEATURES

- Produce more quality ice.
- Crystal clear, hard individual uniquely shaped Crescent cubes that last longer in drinks.
- Use less energy.
- Cycle 1/2 as many times as competition.
- Cubes do not clump together in storage bins.
- Unique stainless steel evaporator design which is unaffected by caustic water, harsh cleaning agents and does not crack or peel like nickel plated evaporators.
- Long life stainless steel construction.
- Inbuilt, removable, easily cleaned, reusable air filters.

TECHNICAL DRAWING



SHAPE OF ICE:

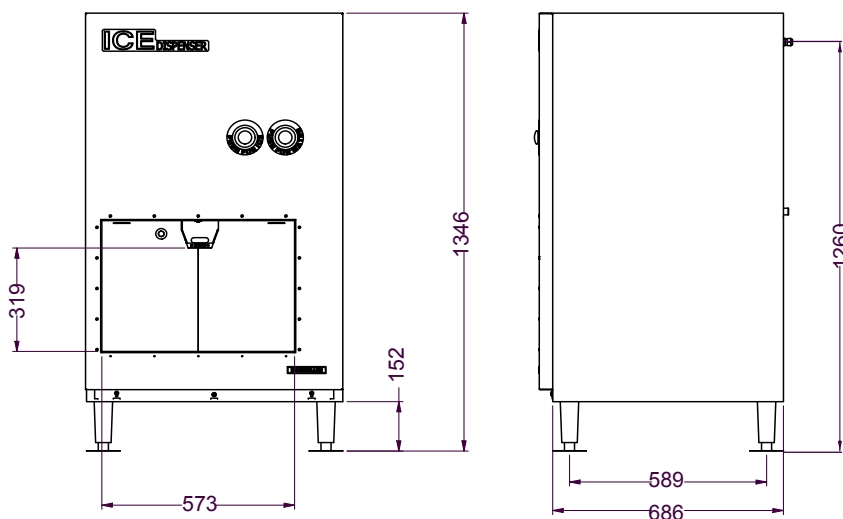

PRODUCT SPECIFICATION

2 Push Buttons - 1 x Ice 1 x Water	Single Auger Agitator
Max Storage Capacity	Approx. 91kg
Dimensions	765mm (W) x 726mm (D) x 1346mm (H)
Production	Select Modular Head unit KMD-201AB, KMD-270AB or KM-660MAJ-E & Top Kit (Sold Separately)
Capacity Volume	5.72 ft ³
Weight Net/Gross (kg)	85
AC Supply Voltage	1 PHASE 240V/ 50Hz /10AMP Plug
Amperage	Rated: 1.4A
Dispensing Rate	5.89 kg
Operating Conditions	Ambient Temp.: 7-38C Voltage Range:104-132V



Descriptions and specifications are subject to change at any time, without notice. Illustrations for demonstration purposes.

Copyright © 2020 Hoshizaki Lancer Pty Ltd. All right reserved. E&OE Date: Sept 2020