



PRODUCT FEATURES

- Produce more quality ice.
- Clear, hard individual uniquely shaped Crescent cubes that last longer in drinks.
- Use less energy.
- Cycle 1/2 as many times as competition.
- Crescent cubes do not clump together in storage bins.
- Unique stainless-steel evaporator design which is unaffected by caustic water, harsh cleaning agents and does not crack or peel like nickel plated evaporators.
- Push-button single auger agitator dispenses ice at 5 kgs. per minute.
- Long-life stainless-steel construction
- Inbuilt, removable, easily cleaned, reusable.
- Compatible Modular Head unit KMD-201AB, KMD-270AB or KM-660MAJ-E or KM-470AJ-S & Top Kit (Sold Separate)



*Ice Machine not included

TECHNICAL DRAWING

FRONT VIEW

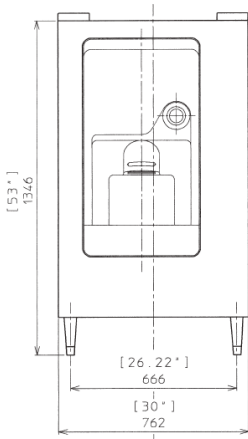

SIDE VIEW

REAR VIEW

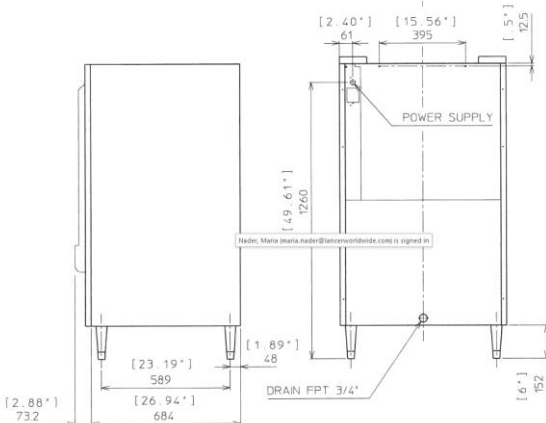

PRODUCT SPECIFICATION

Max Storage Capacity	Approx. 90kg
Dimensions	762mm (W) x 684mm (D) x 1346mm (H)
Dispensing gear motor	60W
Weight Net	85kg
AC Supply Voltage	1 PHASE 240V/50Hz/10AMP Plug
Amperage	Rated:1.4A
Operating Conditions	Ambient Temp.: 7-38°C Voltage Range: 104 -132V
Compatible	KMD-201AB, KMD-270AB or KM-660MAJ-E or KM-470AJ-S & Top Kit (Sold Separate)

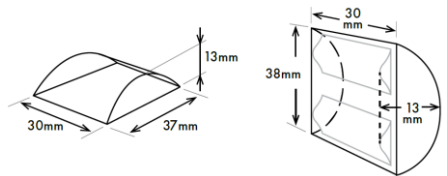

For free 6 month extended warranty, register online within 4 weeks of purchase date.
hoshizaki.com.au

